



WTP series

Washer Tank with integrated Pump



WTP series

washer tank with integrated pump

When you need to integrate into a CCTV system, a washer system, it is important to choose the accessories more efficient. For these solutions GLOBAL PROOF has developed a complete range of washer tanks from 5 litres or 25 litres with 5m, 11m, 19m delivery head and equipped with various power supply integrated solutions: 230-110Vac, 24Vac, 24Vdc e 12Vdc.

- DATA SHEET -

WASHER TANK WITH INTEGRATED PUMP

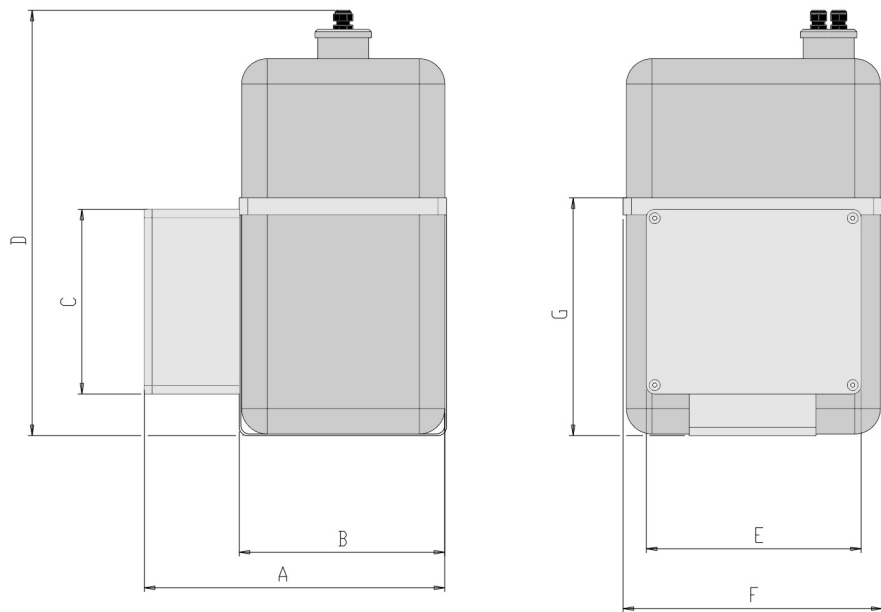

external dimensions (mm.)

	WTP5	WTP25
A	235	310
B	175	250
C	115	115
D	300	495
E	140	140
F	170	245
G	200	282
H	140	140
I	100	100
L	9,5	9,5

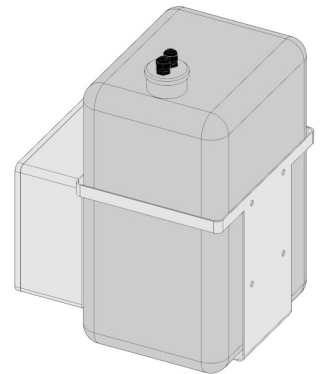
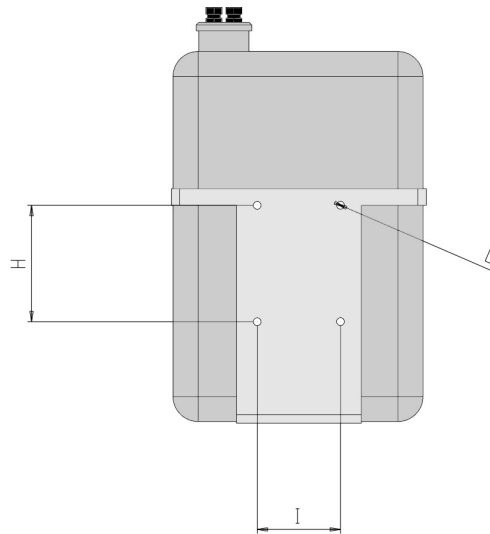

the values are in millimeters

TECHNICAL DATA

GENERAL

- Frame construction: made in AISI304 stainless steel
- Tank material: PEHD (polyethylene high density)
- Pole mounting with SP/B (optional)
- Corner mounting with SA/B (optional)
- Supplied with instruction manual

ELECTRICAL

Input voltage available: 230-110Vac, 24Vac, 24Vdc, 12Vdc

MECHANICAL

- External dimensions: see diagram on the top
- Capability: 5lt o 25lt
- Delivery head: 5m, 11m, 19m

RELATED PRODUCTS

- SP/B** pole adaptor
- SA/B** corner adaptor
- SP/C** stainless steel pole adaptor
- SA/C** stainless steel corner adaptor