

# DATASHEET

## **CRONO CLK305 POE** **aluminium side opening housing** **(IEEE 802.3af-802.3at compliant)**

- side opening housing made of die-cast aluminium
- IP66/67 weatherproof rating
- **IK10** protection (with anti-breaking glass)
- Powered directly by Ethernet cable PoE/PoE+ (802.3af-802.3at compliant)
- integrated wiper (optional, on request)
- extremely easy installation and maintenance
- wide range of optional accessories



### Side opening housing

The housing **CRONO CLK305POE** is designed to simplify installation and maintenance of the most popular medium-large cameras PoE and megapixel, compatible with Ethernet 10/100/Gigabit.

The camera power, heating and ventilation is handled directly from the internal circuit "Smart PoE" (*Italian patent*), in this way it not need any additional external power sources. The die-cast aluminium construction provides high impact resistance and good heat dissipation to the outside while the side opening facilitates accessibility to the camera and connectivity during installation and maintenance.

Available there are a wide range of accessories: anticondensing glass, antibreaking glass, alarm-tamper system, ventilation, high efficiency ventilation system for high temperatures, safety-lock system.

Suitable for every installations of PoE cameras, megapixel, with various lenses.

# DATASHEET

## TECHNICAL DRAWINGS

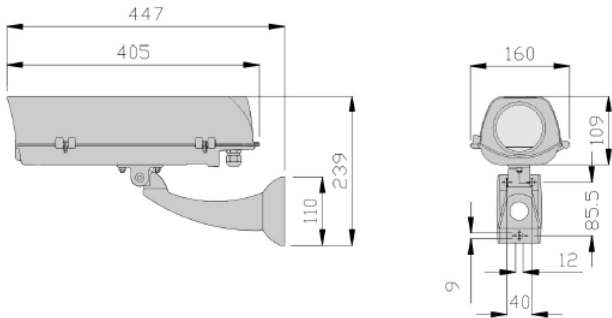
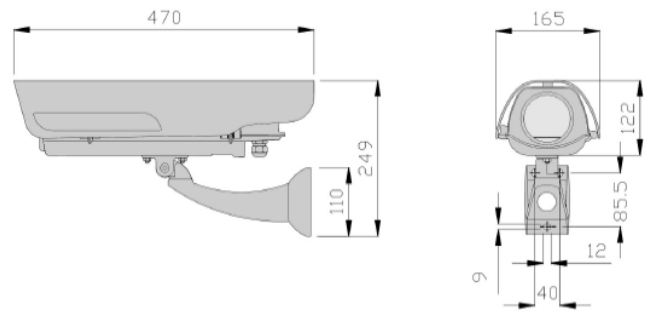
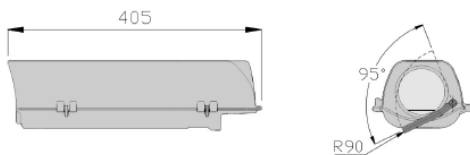
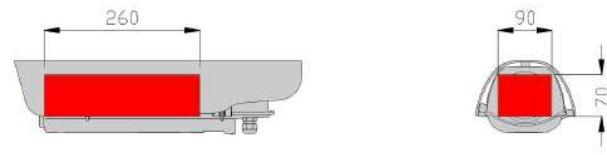
**indoor**

**outdoor**

**integrated wiper version**

**useful area**

*the values are in millimeters*

## TECHNICAL DATA

### GENERAL

- Aluminium body
- UV-resistant technopolymer sunshield with wide range of adjustments.
- RAL 7035 polyester powder coating (light grey).
- Stainless steel bolts and screws.
- Side opening body with captive screws.
- Thermostatically controlled heater.
- Wide range of accessories.
- Supplied with instruction manual.
- According to RoHS compliance.

### ELECTRICAL

- thermostatically controlled heater  
max. power: 5W  
t on: +15°C, t off: +22°C (+/- 3°C)
- thermostatically controlled blower  
max. power: 2W  
t on 37°C t off 27°C +/- 3°C
- integrated wiper:  
max. consumption 5W

### MECHANICAL

- Usable internal space: 90x70mm (WxH).
- Usable length: 260mm.
- Glass window: Ø 75mm.
- IK10 protection with anti-breaking glass.
- Weatherproof rating: IP66/67.
- Weatherproof rating with external ventilation system: IP44.
- Operating temperature with built-in heater: -20°C to +60°C.
- Weight: 2,9 Kg. (kit version).

### ACCESSORIES

- VA305** anti-breaking glass
- VC305** anti-condensation glass
- RP305** double heater
- VI305** built-in blower set
- VE305** high efficiency external ventilation system
- TP305** anti-tamper switch set
- LC305** safety lock for locking the back side of the housing
- WP305** integrated wiper (only preassembled)
- WTP5** 5l. washer tank with integrated pump, 5m/11m/19m delivery head, (three models available)
- WTP25** 25l. washer tank with integrated pump, 5m/11m/19m delivery head, (three models available)

# DATASHEET

**RELATED PRODUCTS**

- STS500** ceiling bracket  
**SP/A** pole adaptor  
**SA/A** corner adaptor  
**PA1** reinforced wall plate for poor consistency walls  
**PA1/SD** reinforced wall plate with junction box for poor consistency walls

model	unit weight (Kg.)	package dimensions (cm.) WxHxL	gross weight (Kg.)
CRONO CLK305POE	2,9	21,0 x 18,8 x 50,0	3,20