

SENTECH

USB 3 Vision Series Datasheet



Features

- USB 3 Vision Compatibility
- 1/1.8" e2v Sensor
- 1.3 MP Resolution
- 60 FPS

Safety / Product Precautions

Safety Precautions

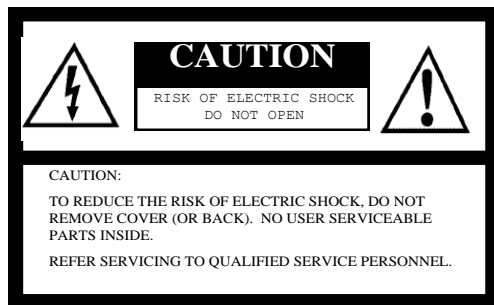

The lightning flash with arrowhead symbol, within an equilateral triangle, is intended to alert the user to the presence of uninsulated “dangerous voltage” within the product’s enclosure that may be of sufficient magnitude to constitute a risk of electric shock to persons.



The exclamation point within an equilateral triangle is intended to alert the user to the presence of important operating and maintenance (servicing) instructions in the literature accompanying the appliance.

For U.S.A.

Warning:

This equipment generates and uses radio frequency energy and if not installed and used properly, i.e., in strict accordance with the instruction manual, may cause harmful interference to radio communications. It has been tested and found to comply with the limits for a Class A computing device pursuant to Subpart J of Part 15 of FCC Rules, which are designed to provide reasonable protection against such interference when operated in a commercial environment.

For Canada

Warning:

This digital apparatus does not exceed the Class A limits for radio noise emissions from digital apparatus set out in the Radio Interference Regulations of the Canadian Department of Communications.

WARNING:

TO PREVENT FIRE OR SHOCK HAZARD, DO NOT EXPOSE THIS APPLIANCE TO RAIN OR MOISTURE.

Product Precautions

- Handle the camera with care. Do not abuse the camera. Avoid striking or shaking it. Improper handling or storage could damage the camera.
- Do not pull or damage the camera cable.
- During camera use, do not wrap the unit in any material. This will cause the internal temperature of the unit to increase.
- Do not expose the camera to moisture, or do not try to operate it in wet areas.
- Do not operate the camera beyond its temperature, humidity and power source ratings.
- While the camera is not being used, keep the lens or lens cap on the camera to prevent dust or contamination from getting in the sensor or filter area and scratching or damaging this area.
- Do not keep the camera under the following conditions:
 - In wet, moist, and high humidity areas
 - Under hot direct sunlight
 - In high temperature areas
 - Near an object that releases a strong magnetic or electric field
 - Areas with strong vibrations
- Apply the power that satisfies the requirements specified in this document to the camera.
- Use a soft cloth to clean the camera. Use pressured air spray to clean the surface of the glass. DO not scratch the surface of the glass.

-
- The camera is a general-purpose electronic device; using the camera for the equipment that may threaten human life or cause dangers to human bodies directly in case of failure or malfunction of the camera is not guaranteed. Use the camera for special purposes at your own risk.
 - Defect pixels may appear due to the sensor characteristics.
 - During camera use, do not plug or unplug other USB devices (USB storage, etc.). Plugging or unplugging other devices may result in a failure to recognize the USB camera.
 - Increasing gain level also increases the noise level.
 - The noise level greatly increases in the long exposure mode.

Notes on PCs with Power Save Mode

When the USB camera is used with a PC that has the power save mode, such as a PC with the Intel Core i3, i5, or i7 CPU, the following problem may occur:

- An image cannot be obtained with the USB camera
- Frames frequently drop

This issue may occur with other USB camera manufactures as well.

[Cause of the Issue]

The PC is unable to transfer the image due to the PC frequently entering the power save mode during the image transfer.

[Solutions for the Issue]

This problem can be avoided by disabling the power save mode. However, depending on the PC, the power save mode cannot be disabled and the desired effect may not be achieved. In addition, when the power save mode is disabled, undesired effects such as an increase of the power consumption and the heat of the PC may occur.

1. Disable the power save mode by changing the BIOS settings.

Either set "ACPI C State" to "Disable" or decrease the "Max ACPI C State" value step by step until you see the effect (i.e. C3->C2->C1). (The setting method and the naming may differ, and/or these settings cannot be changed depending on the PC.)

- Please contact the manufacturer of the PC about the BIOS setting.
- "ACPI C State" and "Max ACPI C State" may have different names depending on the PC.
- Users will be responsible for any change made to the BIOS setting.
- The power consumption and the heat of the PC will increase whenever the power save mode is disabled. Please understand and accept this before disabling the power save mode.

2. Disable the power save mode with the Sentech PC power management software (StPowerCtrl).

Please refer to the Start-up Guide for the details.

3. Change the camera blanking period and reduce the frame rate.

Contents

1	OVERVIEW	6
1.1	FEATURES	6
1.2	NAMING METHOD	6
1.3	SUPPORT APPLICATIONS	6
1.4	USB3 VISION GENICAM COMPLIANCE	6
2	SPECIFICATIONS	7
2.1	ELECTRONIC SPECIFICATIONS	7
2.2	SPECTRAL SENSITIVITY CHARACTERISTICS	8
2.3	MECHANICAL SPECIFICATIONS	9
2.4	ENVIRONMENTAL SPECIFICATIONS	9
3	CONNECTOR SPECIFICATIONS	10
3.1	USB CONNECTOR	10
3.2	I/O CONNECTOR	10
4	INPUT / OUTPUT SIGNAL SPECIFICATIONS	11
4.1	INPUT SIGNALS	11
4.1.1	Input Signal Functions	11
4.1.2	Input Signals Electronic Characteristics	11
4.1.3	Input Signal Circuit	12
4.1.4	Input Signal Circuit Examples	12
4.2	OUTPUT SIGNALS	13
4.2.1	Output Signal Functions	13
4.2.2	Output Signal Electronic Characteristics	15
4.2.3	Output Signal Circuit	16
4.2.4	Output Signal Circuit Examples	16
5	DIMENSIONS	18
6	REVISION HISTORY	19

1 Overview

This document describes the specification of the following cameras.

STC-MBE132U3V / MCE132U3V (1.3M)

1.1 Features

- USB3 Vision
- 60fps (Full scan)
- CMOS Global / Rolling Shutter
- Up to 32 Pixel Defect Correction (Default: ON) *Note1
- 8,10 bit output (RGB8 supports on color camera)

*Note1: Even when the camera is initialized, pixel blemish static collection data will not be initialized on EEPROM. The pixel blemish static collection data on EEPROM can be set after the camera has initialized and the data has been read-out.

1.2 Naming Method

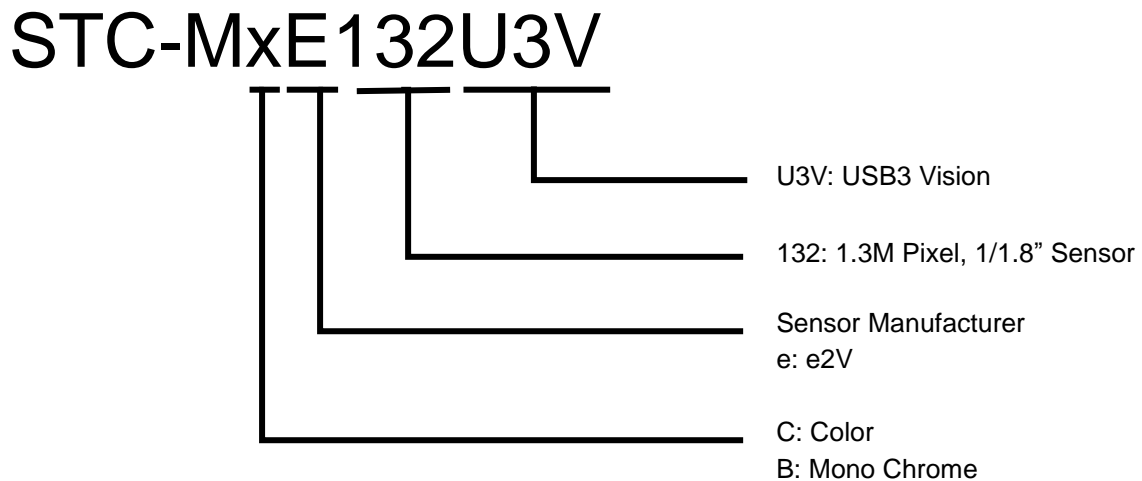

Figure 1: Naming Method

1.3 Support applications

This camera is compatible with USB3 Vision specifications. You can acquire images and control the camera through USB3 Vision compatible vision software only by installing its driver. Also, you can produce an application by utilizing Sentech's SDK's (Standard SDK 3.04, Trigger SDK 3.02 or later). The camera is compatible with GenTL. By installing Sentech's GenTL driver, you can acquire images and control the camera through a GenTL compatible software application.

1.4 USB3 Vision GenIcam Compliance

This product conforms to the USB3 Vision ,GenIcam compliance. When these compliances are updated, this specification may update as well. The product specifications are subject to change without notice.

2 Specifications

2.1 Electronic Specifications

Model Number		STC-MCE132U3V	STC-MBE132U3V
Image Sensor		1/1.8" 1.3M pixel Color CMOS (e2V: EV76C560ACT-EQV)	1/1.8" 1.3M pixel Monochrome CMOS (e2V: EV76C560ABT-EQV)
Active Picture Elements		1280(H) x 1024(V)	
Cell Size		5.3 (H) x 5.3 (V) μ m	
Scanning System		Progressive	
Shutter Type		Rolling Shutter, (Global Reset) / Global Shutter (Selectable)	
Scanning Mode		Full Scanning, Variable AOI (Horizontal and Vertical)	
Maximum Frame Rate (in Full Scanning Mode)		1.3M: 1280 x 1024 : 60fps (Raw8/10 bit), 55fps (RGB8 only on color model) *Frame rate will drop if connected with the USB2.0 port	
Maximum Frame Rate (in Full Scanning Mode and AOI)		XGA (1024 x 768) : 80fps (Raw8/10 bit) , 71fps (RGB8 only on color model) VGA (640 x 480) : 127fps (Raw8/10 bit) , 106fps (RGB8 only on color model) Minimum AOI (32 x 32): 1222fps (Raw8/10 bit, Rolling Shutter), 1270fps (Raw8/10 bit, Global Shutter) Minimum AOI (32 x 32): 416fps (RGB8, Rolling Shutter), 424fps (RGB8, Global Shutter)	
Sync. System		Internal	
Video Output Format		RGB8, RAW8bit/10bit,	RAW8bit/10bit
S/N Ratio (8bit)		Less than 3 digit(Gain 0 dB)	
Minimum Scene Illumination		28.14lx at F1.2	0.26lx at F1.2
ALC		Auto Shutter / Auto Gain (Default: OFF)	
Electronic Shutter		Preset • Free-run Mode: Exposure Time 16 usec to 0.97 sec (in full scanning mode) Preset • Trigger Mode: Exposure Time 16 usec to 0.97 sec (in full scanning mode)	
Gain	Analog	0 to 11.97dB (Default: 0dB)	
	Digital	x0.00 to x7.98 (Default: x0.00)	
Offset	Digital	0 to 255 digit on 12bit (Default: 168)	
AOI		AOI (Horizontal : 32 to 1280 pixels / Vertical : 32 to 1024 Line) (Default: 1280 x 1024) Adjustable Steps: 4 pixels in horizontal direction and 4 lines in vertical direction	
Binning Function		Horizontal 1/2, Vertical 1/2, (Default: 1/1) *Pixels in the horizontal and vertical direction can be added to increase the brightness. Available on "Horizontal and Vertical"	
Skipping Function		Horizontal 1/2, 1/4, Vertical 1/2, 1/4 (Default: 1/1)	
Mirror Image		Horizontal / Vertical / Horizontal and Vertical (Default: OFF)	
Pixel Defect Correction		Up to 32 pixels (Default: ON)	
White Balance		Auto / Manual/ One-shot (Default: Manual)	N/A
Operational Mode		Free-run / Edge-preset Trigger	
Frame Memory		One Frame	
Interface		USB3.0 Super speed (USB3.0 Micro B)	
Input / Output		Two Inputs and Two Outputs	
Power	Input Voltage	+5V(typ.) (Conform to USB Standard)	
	Consumption	Less than 2.0 W	

Table 1: Electronic Specifications (STC-MCE132U3V/ STC-MBE132U3V)

2.2 Spectral Sensitivity Characteristics

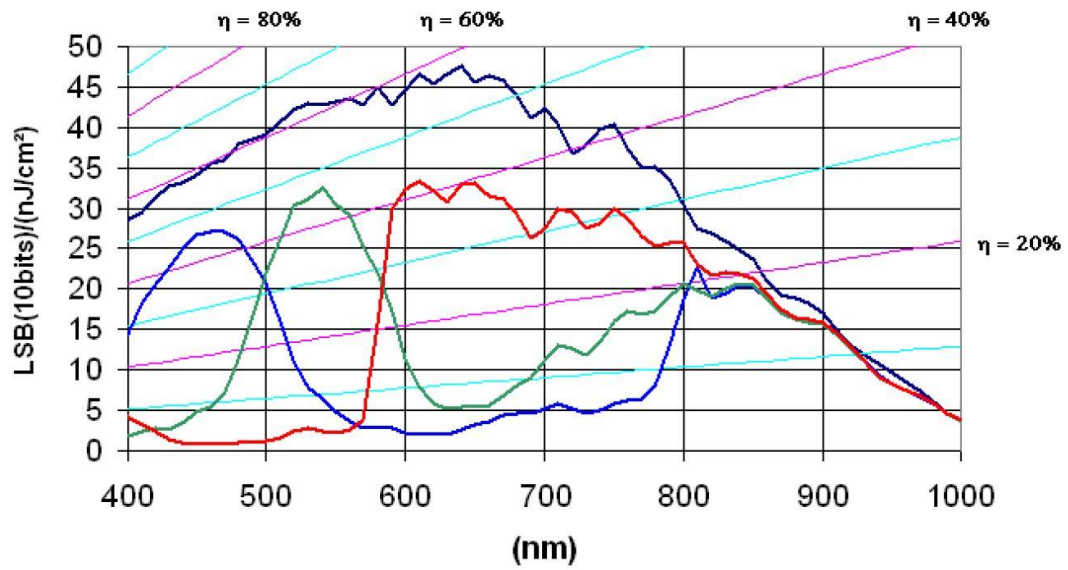

Figure 2. Spectral Sensitivity Characteristics (STC-MCE132U3V/ MBE132U3V)

IR Cut Filter(NF-50D)

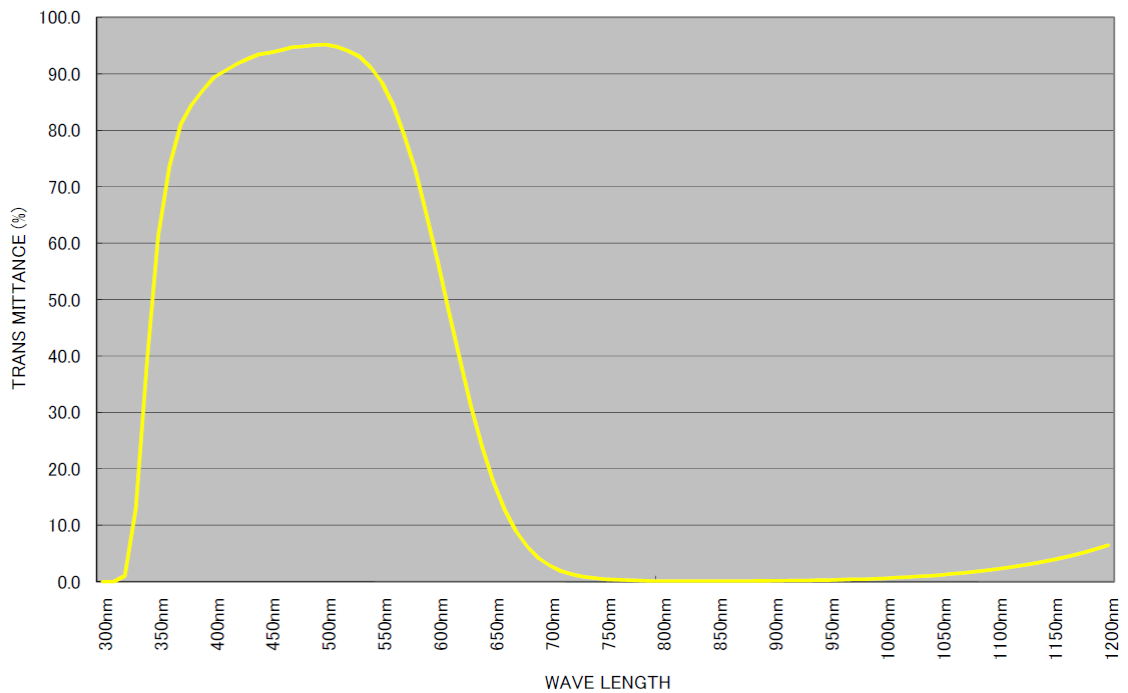

Figure 3: IR Cut Filter Characteristics (STC-MBE132U3V)

2.3 Mechanical Specifications

Model Number	STC-MCE132U3V	STC-MBE132U3V
Dimensions	28 (W) x 28 (H) x 33.8 (D) mm *excluding the connectors	
Lens Mount	CS Mount	
Optical Filter	IR Cut Filter	No IR Cut Filter
Optical Center Accuracy	Positional accuracy in H and V directions: +/- 0.5 mm Rotational accuracy of H and V: +/- 0.35 deg.	
Weight	Approx. 38 g	
Interface Connectors	USB Connector: USB3.0 MicroB type I/O Connector: HR10A-7R-6PB (Hirose) or equivalent	

Table 2: Mechanical Specifications

2.4 Environmental Specifications

Model Number	STC-MBE132U3V / STC-MCE132U3V
Operational Temperature	0 ~ +40°C
Storage Temperature	-30 ~ +65°C
Vibration	20Hz to 200Hz to 20Hz (5min./cycle), acceleration 10G, 3 directions 30 min. each
Shock	Acceleration 38G, half amplitude 6ms, 3 directions 3 times each
Standard Compliancy	EMS: EN61000-6-2, EMI: EN55011
RoHS	RoHS Compliant

*As for the “tested connection host controller”. Please see Application note.

Table 3: Environmental Specifications

3 Connector Specifications

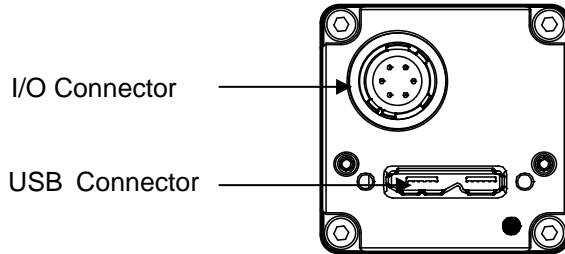

Figure 1: Back View

3.1 USB Connector

- USB3.0 micro-B type

3.2 I/O Connector

- HR10A-7R-6PB (Hirose) or equivalent.
- This connector is for input triggers and output signals.
- Use mating connector HR10A-7P-6S (Hirose) or equivalent.
- The Power Input (IO_Vcc) on pin number 6 is only for the output circuits and it is not for the camera main power input. The camera main power is supplied through the USB connector.

Pin Assignment

Pin No.	Signal Name	IN / OUT	Voltage	
			Low	High
1	GND (IO_GND)	-	0V	
2	Output 2 (IO3)	OUT	Smaller than 0.8 V	+3.3 to +24 V
3	Output 1 (IO2)	OUT	Smaller than 0.8 V	+3.3 to +24 V
4	Input 2 (IO1)	IN	Smaller than 0.7 V	+2.5 to +5 V
5	Input 1 (IO0)	IN	Smaller than 0.7 V	+2.5 to +5 V
6	Power Input (IO_VCC)	-	+3 to +24Vdc	

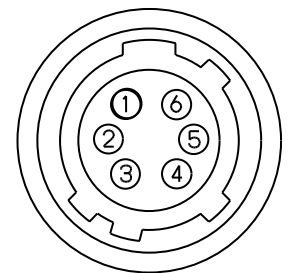

[Back Side]

Table 4: Pin Assignment

4 Input / Output Signal Specifications

4.1 Input Signals

4.1.1 Input Signal Functions

- Using the software, the following functions can be set on "Input 1" and "Input 2" of the I/O connector.
- The polarity of Trigger Input is also selectable.

Function No.	Function Name	Polarity
1)	Disabled (Default)	-
2)	General Input	-
3)	Trigger Input	Positive or Negative

Table 5: Input Signals function table

- 1) Disabled
Set this signal when no input signal is necessary.
- 2) General Input
When "General Input" is selected, the user can input high or low signals through this input. Once this has been completed, the state of the "General Input" can be read by applications.
- 3) Trigger Input
Use this function for the trigger signal in the edge preset mode.

4.1.2 Input Signals Electronic Characteristics

- Input Signal / Input Voltage: 0 to 5V
- Input Signal / Voltage Level
 - High Level: 2.5V (min.)
 - Low Level: 0.7V (max.)

4.1.3 Input Signal Circuit

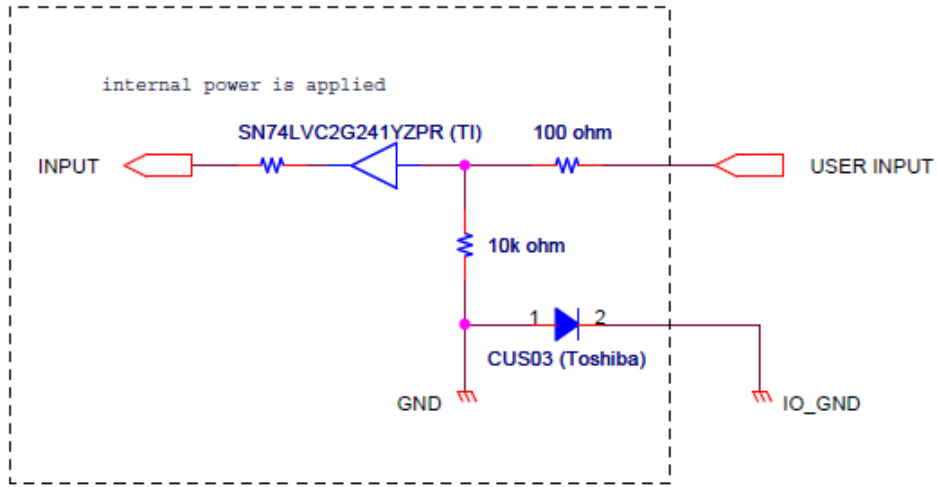

Figure 4: Input Signal Circuit

4.1.4 Input Signal Circuit Examples

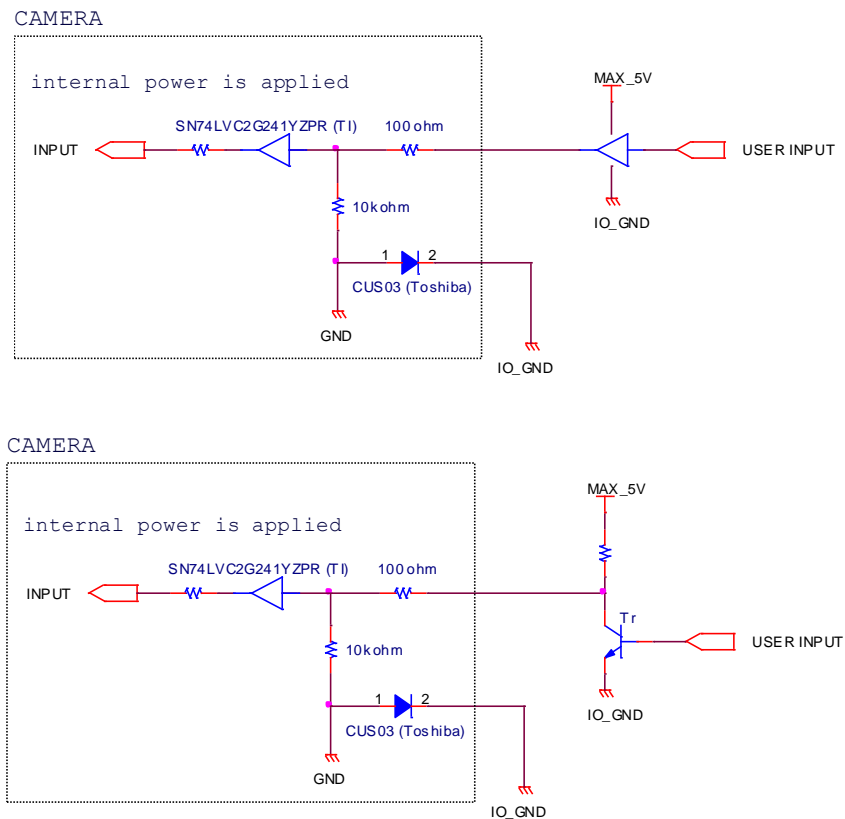

Figure 5. Input Signal Circuit Examples

Caution!!

*The voltage applied on “input 1” or “input 2” must be less than or equal to 5V, the absolute maximum input voltage.

4.2 Output Signals

4.2.1 Output Signal Functions

- Using the software, the following functions can be set on “Output 1” and “Output 2” of the I/O connector.
- The polarity of Trigger Output Programmable, Trigger Output Loop Through, Exposure End, CCD Read End Output, Strobe Output Programmable, Strobe Output Exposure and Trigger Valid Out is selectable.
- It is recommended to use Negative Polarity in order to reduce the timing delay due to open corrector output.

Function No.	Function Name	Polarity
1)	Disabled (Default)	-
2)	General Output	-
3)	Trigger Output Programmable	Positive or Negative
4)	Trigger Output Loop Through	Positive or Negative
5)	Exposure End	Positive or Negative
6)	Read End Output	Positive or Negative
7)	Strobe Output Programmable	Positive or Negative
8)	Strobe Output Exposure	Positive or Negative
9)	Trigger Valid Out	Positive or Negative

Table 6: Input Signals function table

- 1) Disabled
Set this signal when no output signal is necessary.
- 2) General Output
This signal outputs high or low level signal set on the software.
- 3) Trigger Output Programmable
This signal outputs the trigger input signal with preset delay time.
- 4) Trigger Output Loop Through
This signal outputs the trigger input signal (with a slight internal delay).
- 5) Exposure End
When global shutter is selected, this signal is enabled when the exposure is finished. When rolling shutter is selected, this signal is enabled when the exposure of the first line is finished.
(The "Trigger Out Delay" and "Trigger Pulse Width" settings are applied.)
- 6) Read End Output
This signal outputs a signal upon the completion of the transfer of a full frame.
(The "Trigger Out Delay" and "Trigger Pulse Width" settings are applied.)
- 7) Strobe Output Programmable
This output is provided to drive external strobe. The output starts when the trigger input is enabled and ends at the end of sensor exposure. Individual delay times are set at the start and at the end.

8) Strobe Output Exposure

When global shutter is selected, this signal is enabled while the exposure occurs. When rolling shutter is selected, this signal is enabled while the exposure of the first line occurs.

9) Trigger Valid Out

This output provides the acceptable timing for trigger input signal. Trigger signal is accepted when this output is enabled, and it is not accepted when this output is disabled. The disabled period is from the beginning of the exposure to the end of the data readout.

*Because this camera is a rolling shutter type, the exposure start timing of each line is not simultaneous.

4.2.2 Output Signal Electronic Characteristics

➤ Output Signal / Voltage Level

High Level: Power Input of the I/O Connector (+3.3 ~ +24 V)
 Low Level: Smaller than 0.8 V

➤ Output Signal / Pulse Width

Pulse width duration periods of some of the output signals are programmable. The drawing and the table shown below display the delay time based on different Vcc voltages. The user should consider the delays when designing any system with output signals from the camera.

➤ Output Signal / Response Timing

The response timing shown below is a reference value measured without an external resistance.

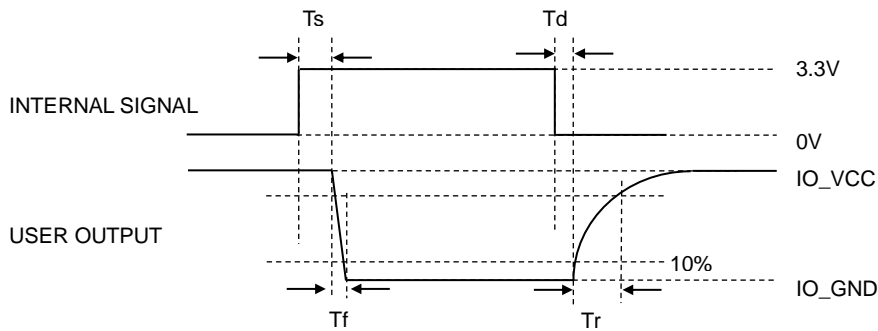

	IO_VCC			
	3.3[V]	5.0[V]	12[V]	24[V]
Td	2.00 [us]	1.82 [us]	1.66 [us]	1.60 [us]
Tr	0.82 [us]	0.84 [us]	1.16 [us]	1.44 [us]
Ts	0.50 [us]	0.56 [us]	0.56 [us]	0.70 [us]
Tf	0.56 [us]	0.66 [us]	1.16 [us]	2.04 [us]

4.2.3 Output Signal Circuit

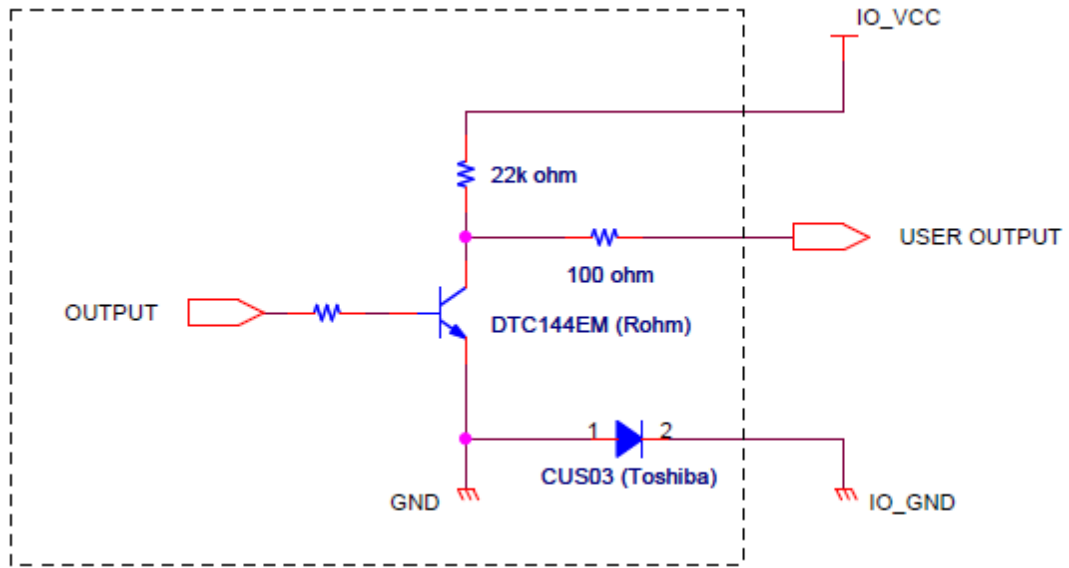
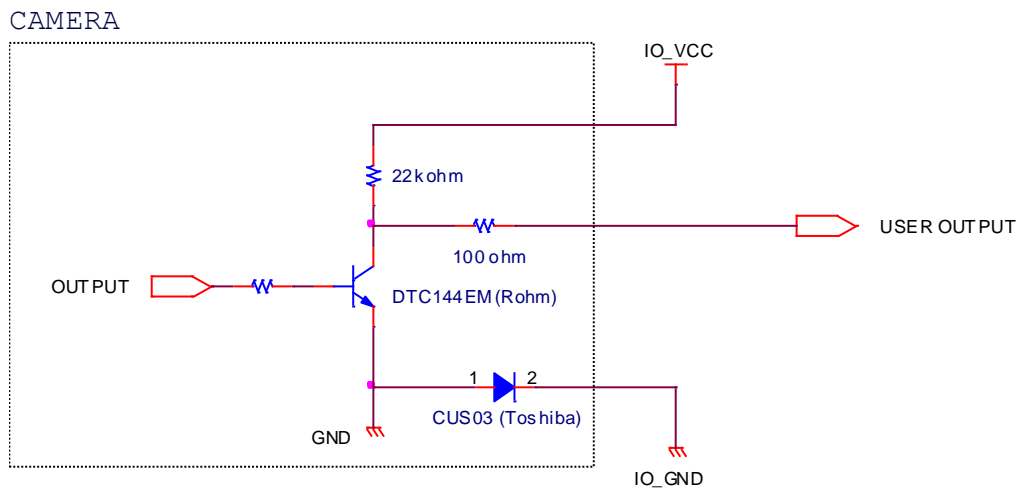

Figure 6: Output Signal Circuit

4.2.4 Output Signal Circuit Examples



*The voltage applied on "IO_VCC" must be within the range of +3.3V to +24V.

Figure 7: Output Signal Circuit Examples

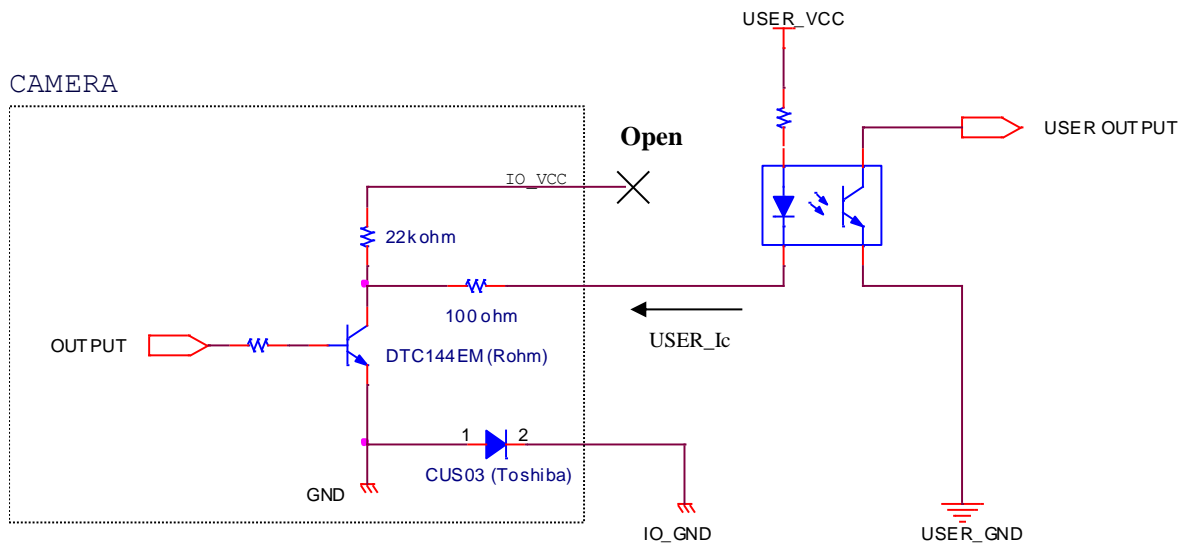

- *When no voltage is applied on "IO_VCC", it can be used as an open collector output.
- *The voltage applied on "IO2" and "IO3" (USER_VCC) must be less than or equal to 24V.
- *The incoming current to "IO2" and "IO3" (USER_Ic) must be less than or equal to 15mA.

Figure 8: Output Signal Circuit Examples1

5 Dimensions

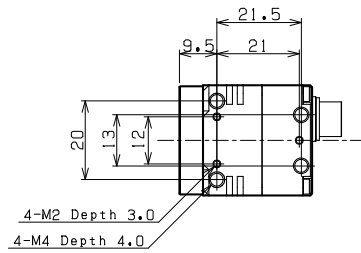
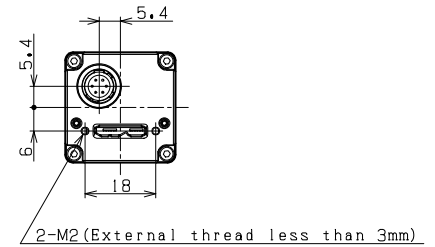
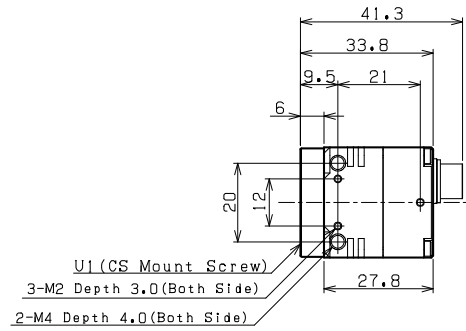
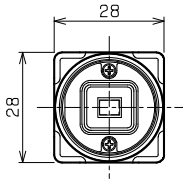
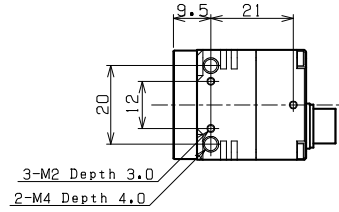
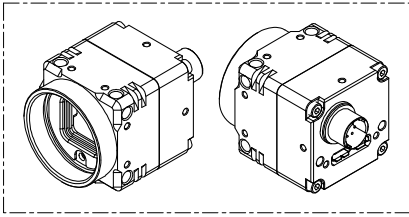

Unit: mm

*How to Identify Monochrome and Color Camera

STC-MBE132U3V

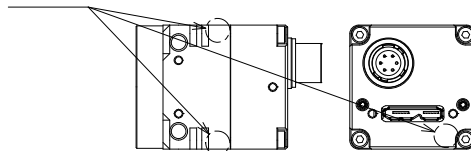

STC-MCE132U3V

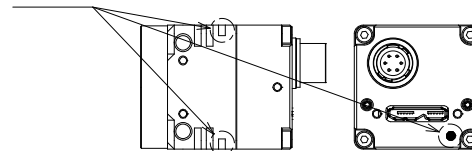

6 Revision History

Rev	Date	Changes	Note
1.00	2013/08/30	<ul style="list-style-type: none">● New Document	
1.01	2013/09/13	<ul style="list-style-type: none">● Update Revised: Minimum Scene Illumination ,SN	
1.02	2013/9/24 2014/03/17	<ul style="list-style-type: none">● Update Added: Sensor Model (small suffix). Larger Spectral Sensitivity chart Revised: Power Consumption	
1.03	2014/07/23	<ul style="list-style-type: none">● Updated documentation to Full English Translation version	RM

Sensor Technologies America, Inc.

1345 Valwood Pkwy, Suite 320

Carrollton, TX 75006

TEL: (972)-481-9223

FAX: (972)-481-9209

www.SentechAmerica.com

Sensor Technology Co., Ltd

7F, Harada center building

9-17, Naka cho 4 chome

Atsugi-city, Kanagawa

243-0018 Japan

TEL +81-46-295-7061 FAX +81-46-295-7066

URL <http://www.sentech.co.jp/>