

SENTECH

STC-MC33USB / MB33USB (VGA)

STC-MC83USB / MB83USB (XGA)

STC-MC133USB / MB133USB (SXVGA)

STC-MC152USB / MB152USB (SXGA)

STC-MC202USB / MB202USB (UXGA)

Product Specification

Small Hardware

Software Trigger USB 2.0

Color / Monochrome Cameras

Safety Precautions

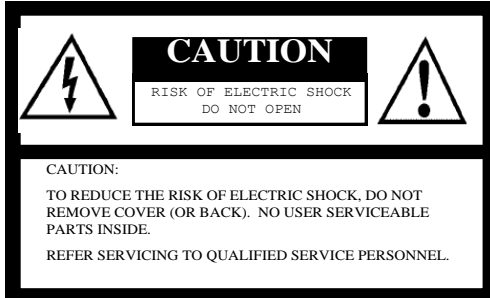

The lightning flash with arrowhead symbol, within an equilateral triangle, is intended to alert the user to the presence of uninsulated “dangerous voltage” within the product’s enclosure that may be of sufficient magnitude to constitute a risk of electric shock to persons.



The exclamation point within an equilateral triangle is intended to alert the user to the presence of important operating and maintenance (servicing) instructions in the literature accompanying the appliance.

For U.S.A.

Warning:

This equipment generates and uses radio frequency energy and if not installed and used properly, I.e., in strict accordance with the instruction manual, may cause harmful interference to radio communications. It has been tested and found to comply with the limits for a Class A computing device pursuant to Subpart J of Part 15 of FCC Rules, which are designed to provide reasonable protection against such interference when operated in a commercial environment.

For Canada

Warning:

This digital apparatus does not exceed the Class A limits for radio noise emissions from digital apparatus set out in the Radio Interference Regulations of the Canadian Department of Communications.

WARNING:

TO PREVENT FIRE OR SHOCK HAZARD, DO NOT EXPOSE THIS APPLIANCE TO RAIN OR MOISTURE.

Product Precautions

- Handle the camera with care. Do not abuse the camera. Avoid striking or shaking it. Improper handling or storage could damage the camera.
- Do not pull or damage the camera cable.
- During camera use, do not wrap the unit in any material. This will cause the internal temperature of the unit to increase.
- Do not expose the camera to moisture, or do not try to operate it in wet areas.
- Do not operate the camera beyond its temperature, humidity and power source ratings.
- While the camera is not being used, keep the lens or lens cap on the camera to prevent dust or contamination from getting in the CCD or filter area and scratching or damaging this area.
- Do not keep the camera under the following conditions:
 - In wet, moist, and high humidity areas
 - Under hot direct sunlight
 - In high temperature areas
 - Near an object that releases a strong magnetic or electric field
 - Areas with strong vibrations
- Use a soft cloth to clean the camera. Use pressured air spray to clean the surface of the glass. Do not scratch the surface of the glass.

Copyright & Disclaimer

Sensor Technologies America, Inc. (DBA Sentech America) believes the contents and specifications of its website, catalog, documentation and ads are correct; however, Sentech America provides no representation or warranty regarding such information or product(s) contained therein. It is requested that Sentech America be given appropriate acknowledgement in any subsequent use of such work by a third party.

While every effort has been made to ensure that the details contained in Sentech America's website and all documentation are correct and up-to-date, Sentech America assumes no liability, legal or otherwise for any errors in listings, specifications, part numbers, process, software or model applications. Sentech America reserves the right to change specifications, product descriptions, product quality, pricing and application at any time without prior written or oral notice. Any party using such information assumes all risk for any and all damaged caused to themselves, a third party and/or property by virtue of incorrect information and/or failure of these products. By installing and/or using a Sentech America software development kit or other similar product and/or information obtained from Sentech America's website, catalog, documentation or ads, you hereby accept and understand these stated terms and conditions.

Contents

I. Specifications	1
A. Electronic Specifications / Mechanical Specifications / Environmental Specifications	2
1. STC-MC33USB / STC-MB33USB.....	6-7
2. STC-MC83USB / STC-MB83USB.....	8-9
3. STC-MC133USB / STC-MB133USB.....	10-11
4. STC-MC152USB / STC-MB152USB.....	12-13
5. STC-MC202USB / STC-MB202USB.....	14-15
B. Interface Connector	16
C. Input / Output Signal Specifications	17-20
II. Dimensions	21-24

Caution for PCs with Intel Core i3, i5 or i7

- If the USB camera is used with a PC that has the Intel Core I series (i3, i5 and i7) chipset, the following problems may occur:

- An image cannot be obtained with the USB camera
- Frequent frame drop

This issue may occur with other USB camera manufacturers as well.

- Cause of the issue:

The image data cannot transfer to the PC because the Intel Core i3, i5 or i7 CPU frequently switches to the power save mode while the image is transferring.

- Solutions for the issue:

1. Disable the power save mode by changing the BIOS settings.

Users will be responsible for any changes made to the BIOS setting.

The power consumption and the heat of the PC will increase whenever the power save mode is disabled. Please understand and accept this before disabling the power save mode.

2. Disable the power save mode with the Sentech PC power management software (StPowerCtrl)

The power save mode can be disabled with the Sentech PC power management software "StPowerCtrl".

- A. Install "StCamSWare(v1.10)" or later revision.
- B. Launch "StPowerCtrl" from Windows start => Sentech => StCamSWare.
- C. Disable the two check boxes.

Before:

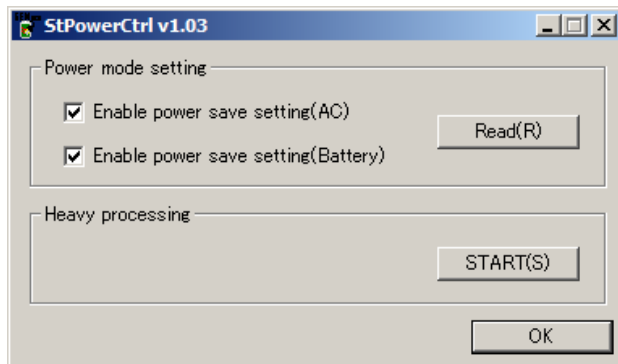

After:

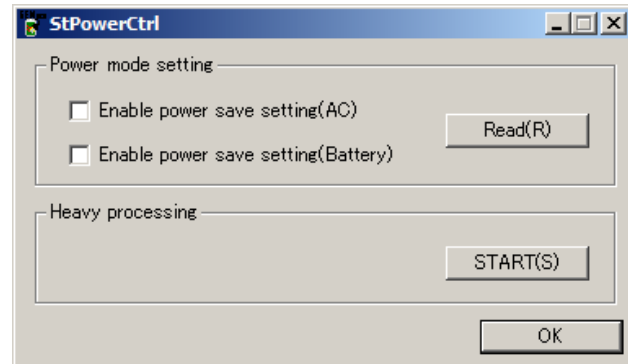

The power consumption and heat of the PC will increase when the power save mode is disabled. Please understand and accept this before disabling the power save mode.

3. Change the camera clock from "Normal" to "½" or "¼". (This will reduce the frame rate)

I. Specifications

A. Electronic Specifications / Mechanical Specifications / Environmental Specifications

1. STC-MC33USB / STC-MB33USB

Product		STC-MC33USB	STC-MB33USB	
Electronic Specifications	Image Sensor	1/3" Interline VGA color progressive CCD: ICX424AQ (Sony)	1/3" Interline VGA monochrome progressive CCD: ICX424AL (Sony)	
	Total Picture Element	692 (H) x 504 (V)		
	Effective Picture Element	640 (H) x 494 (V)		
	Chip Size	5.79 (H) x 4.89 (V) mm		
	Cell Size	7.40 (H) x 7.40 (V) μm		
	Scanning Systems	Progressive		
	Resolution	640 (H) x 480 (V) (Full scanning) 640 (H) x 224 (V) (1/2 partial scanning) 640 (H) x 80 (V) (1/4 partial scanning)		
	Scanning Methods	Full scanning 1/1 partial scanning 1/2 partial scanning 1/4 partial scanning Variable partial scanning	Full scanning, 1/1 partial scanning, 1/2 partial scanning, 1/4 partial scanning, Variable partial scanning, Binning scanning, Binning 1/1 partial scanning, Binning 1/2 partial scanning, Binning 1/4 partial scanning, Binning variable partial scanning	
	Maximum Frame Rate	Full Scanning	59.94 fps (Normal) / 29.97 fps (1/2 clock) / 14.98 fps (1/4 clock) / 89.91 fps (1/2 clock)	
		1/2 Partial Scanning	120.11 fps (Normal) / 60.05 fps (1/2 clock) / 30.02 fps (1/4 clock) / 180.165 fps (1/2 clock)	
		1/4 Partial Scanning	240.22 fps (Normal) / 120.11 fps (1/2 clock) / 60.055 fps (1/4 clock) / 360.33 fps (1/2 clock)	
	Pixel Frequency	24.5454MHz (Normal) / 12.2727MHz (1/2 clock) / 6.13635MHz (1/4 clock) / 36.818MHz (1/2 clock)		
	Video Output	8bit / 10bit / 12bit		
	Minimum Scene Illumination	18 Lux at F1.2	0.17 Lux at F1.2	
	Sync. System	Internal		
	Electronic Shutter		Auto / Manual (software selectable)	
		Normal	1/24,545,455 to 1/59.94 seconds	
		1/2 Clock	1/12,272,727 to 1/29.97 seconds	
		1/4 Clock	1/6,136,364 to 1/14.99 seconds	
	Gain	Auto / Manual (software selectable)		
Gamma	Manual (software selectable)			
White Balance	Auto / Manual / One shot (software selectable)	-		
Trigger Mode	Free-run / Edge preset trigger / Pulse width trigger / Start & stop trigger (software selectable)			
Input/Output	USB 2.0 High Speed			
Power	Input Voltage	+5Vdc through USB connector (+4.4 to +5.25V)		
	Consumption	< 420 mA		
Mechanical Specifications	Dimensions	28 (W) x 28 (H) x 37 (D) mm (excluding connector)		
	Lens Mount	CS mount		
	Weight	Approximately 45g		
	Interface Connector	USB: mini-B USB connector IO signal: 6pin connector (HR10A-7R-6PB or equivalent)		
Environmental Specifications	Operational Temperature	0°C ~ 40°C		
	Storage Temperature	-30°C ~ 65°C		
	Vibration	20 Hz to 200Hz to 20Hz (5min./cycle), acceleration 10G, 3 directions 30 min. each		
	Shock	Acceleration 70G, half amplitude 6ms, 3 directions 3 times each		
	Standard Compliancy	EMS: En61000-6-2, EMI: EN61000-6-3 (Class B)		
RoHS	RoHS Compliant			

Caution: Please DO NOT connect or disconnect any USB devices (including the USB memory) while using the Sentech USB camera; this may cause the USB camera to NOT be recognized.

Spectral Sensitivity Characteristics

STC-MC33USB (with IR cut filter)

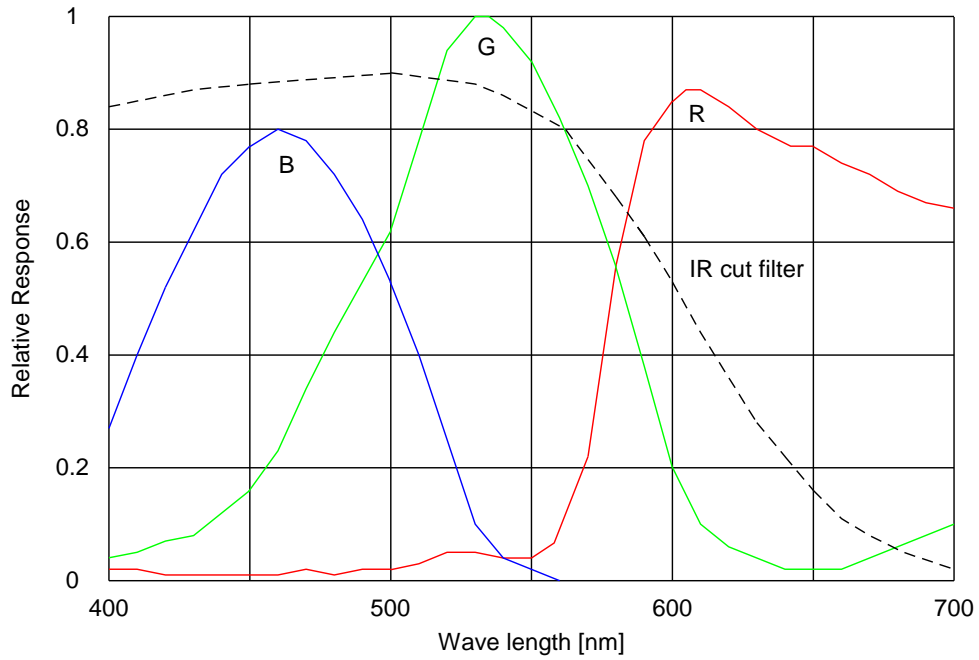

STC-MB33USB

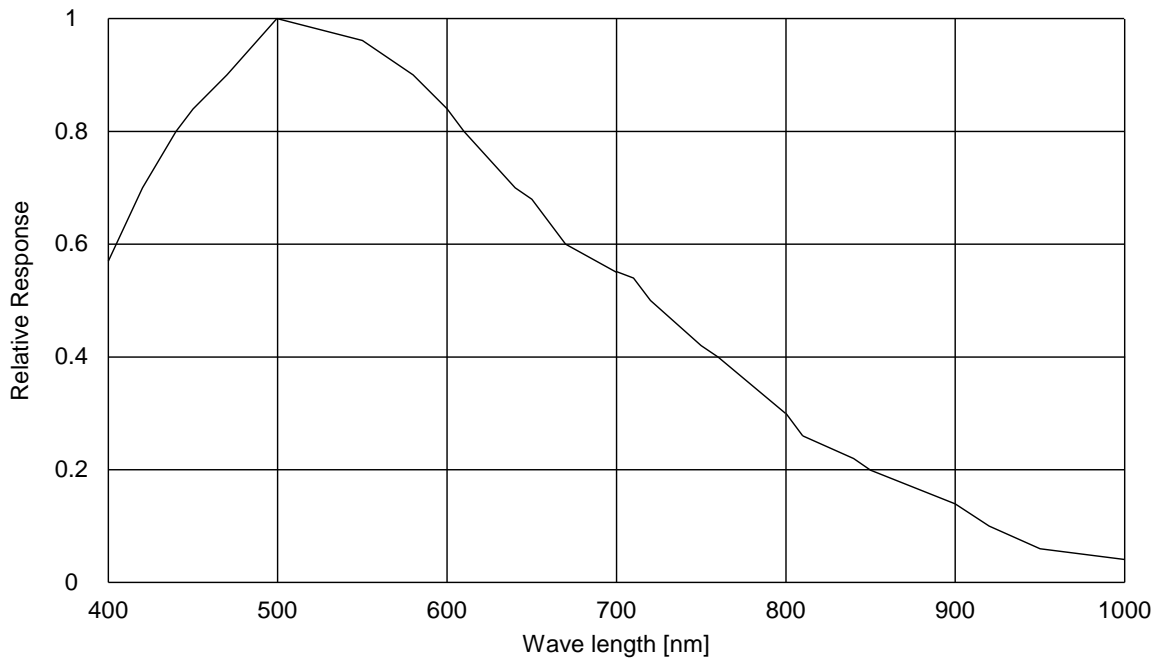

2. STC-MC83USB/STC-MB83USB

Product		STC-MC83USB	STC-MB83USB	
Electronic Specifications	Image Sensor	1/3" Interline XGA color progressive CCD: ICX204AK (Sony)	1/3" Interline XGA monochrome progressive CCD: ICX204AL (Sony)	
	Total Picture Element	1077 (H) x 788 (V)		
	Effective Picture Element	1024 (H) x 779 (V)		
	Chip Size	5.80 (H) x 4.92 (V) mm		
	Cell Size	4.65 (H) x 4.65 (V) μm		
	Scanning Systems	Progressive		
	Resolution	1024 (H) x 768 (V) (Full scanning) 1024 (H) x 344 (V) (1/2 partial scanning) 1024 (H) x 136 (V) (1/4 partial scanning)		
	Scanning Methods	Full scanning 1/1 partial scanning 1/2 partial scanning 1/4 partial scanning Variable partial scanning	Full scanning, 1/1 partial scanning, 1/2 partial scanning, 1/4 partial scanning, Variable partial scanning, Binning scanning, Binning 1/1 partial scanning, Binning 1/2 partial scanning, Binning 1/4 partial scanning, Binning variable partial scanning	
	Maximum Frame Rate	Full Scanning	29.18 fps (Normal) / 14.59 fps (1/2 clock) / 7.295 fps (1/4 clock)	
		1/2 Partial Scanning	60.02 fps (Normal) / 30.01 fps (1/2 clock) / 15.00 fps (1/4 clock)	
		1/4 Partial Scanning	120.35 (Normal) / 60.175 fps (1/2 clock) / 30.087 fps (1/4 clock)	
	Pixel Frequency	29.5 MHz (Normal) / 14.75 MHz (1/2 clock) / 7.375 MHz (1/4 clock)		
	Video Output	8bit / 10bit / 12bit		
	Minimum Scene Illumination	21 Lux at F1.2	0.54 Lux at F1.2	
	Sync. System	Internal		
	Electronic Shutter		Auto / Manual (software selectable)	
		Normal	1/29,500,000 to 1/29.18 seconds	
		1/2 Clock	1/14,750,000 to 1/14.59 seconds	
		1/4 Clock	1/7,375,000 to 1/7.30 seconds	
	Gain	Auto / Manual (software selectable)		
Gamma	Manual (software selectable)			
White Balance	Auto / Manual / One shot (software selectable)	-		
Trigger Mode	Free-run / Edge preset trigger / Pulse width trigger / Start & stop trigger (software selectable)			
Input/Output	USB 2.0 High Speed			
Power	Input Voltage	+5Vdc through USB connector (+4.4 to +5.25V)		
	Consumption	< 420 mA		
Mechanical Specifications	Dimensions	28 (W) x 28 (H) x 37 (D) mm (excluding connector)		
	Lens Mount	CS mount		
	Weight	Approximately 45g		
	Interface Connector	USB: mini-B USB connector IO signal: 6pin connector (HR10A-7R-6PB or equivalent)		
Environmental Specifications	Operational Temperature	0°C ~ 40°C		
	Storage Temperature	-30°C ~ 65°C		
	Vibration	20 Hz to 200Hz to 20Hz (5min./cycle), acceleration 10G, 3 directions 30 min. each		
	Shock	Acceleration 70G, half amplitude 6ms, 3 directions 3 times each		
	Standard Compliancy	EMS: EN61000-6-2, EMI: EN61000-6-3 (Class B)		
	RoHS	RoHS Compliant		

Caution: Please DO NOT connect or disconnect any USB devices (including the USB memory) while using the Sentech USB camera; this may cause the USB camera to NOT be recognized.

Spectral Sensitivity Characteristics

STC-MC83USB (with IR cut filter)

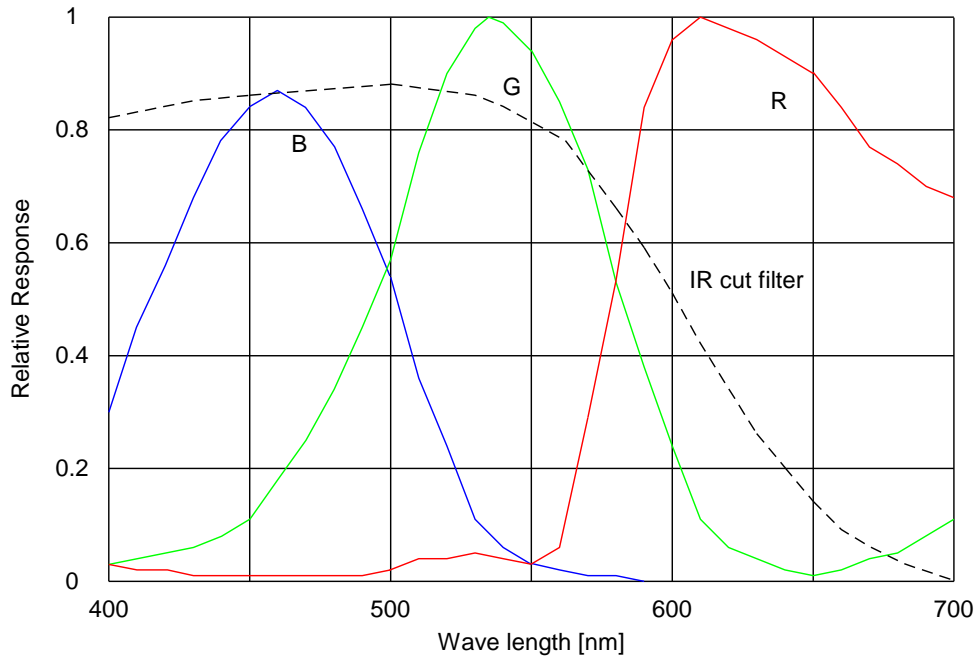

STC-MB83USB

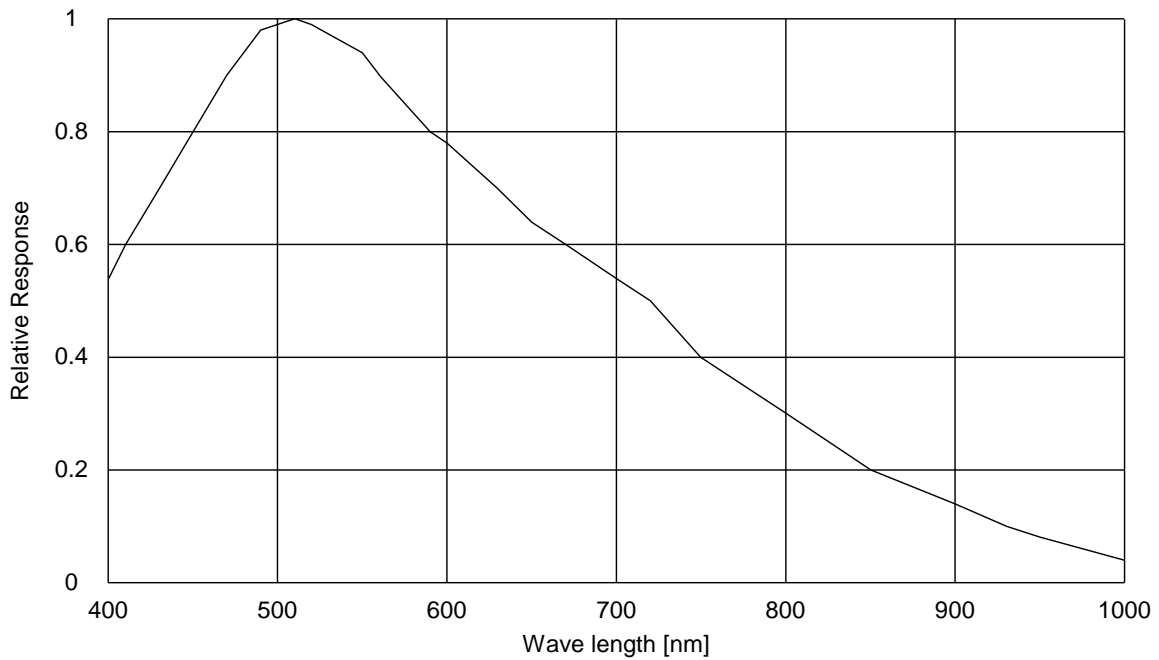

3. STC-MC133USB/STC-MB133USB

Product		STC-MC133USB	STC-MB133USB	
Electronic Specifications	Image Sensor	1/3" Interline SXVGA color progressive CCD: ICX445AQ (Sony)	1/3" Interline SXVGA monochrome progressive CCD: ICX445AL (Sony)	
	Total Picture Element	1348 (H) x 976 (V)		
	Effective Picture Element	1280 (H) x 966 (V)		
	Chip Size	6.26 (H) x 5.01 (V) mm		
	Cell Size	3.75 (H) x 3.75 (V) μm		
	Scanning Systems	Progressive		
	Resolution	1280 (H) x 960 (V) (Full scanning) 1280 (H) x 440 (V) (1/2 partial scanning) 1280 (H) x 168 (V) (1/4 partial scanning)		
	Scanning Methods	Full scanning 1/1 partial scanning 1/2 partial scanning 1/4 partial scanning Variable partial scanning	Full scanning, 1/1 partial scanning, 1/2 partial scanning, 1/4 partial scanning, Variable partial scanning, Binning scanning, Binning 1/1 partial scanning, Binning 1/2 partial scanning, Binning 1/4 partial scanning, Binning variable partial scanning	
	Maximum Frame Rate	Full Scanning	22.40 fps (Normal) / 11.20 fps (1/2 clock) / 5.60 fps (1/4 clock)	
		1/2 Partial Scanning	44.81 fps (Normal) / 22.40 fps (1/2 clock) / 11.20 fps (1/4 clock)	
		1/4 Partial Scanning	89.80 fps (Normal) / 44.90 fps (1/2 clock) / 22.45 fps (1/4 clock)	
	Pixel Frequency	36.818 MHz (Normal) / 18.409 MHz (1/2 clock) / 9.20453 MHz (1/4 clock)		
	Video Output	8bit / 10bit / 12bit		
	Minimum Scene Illumination	11 Lux at F1.2	0.15 Lux at F1.2	
	Sync. System	Internal		
	Electronic Shutter		Auto / Manual (software selectable)	
		Normal	1/36,818,182 to 1/22.40 seconds	
		1/2 Clock	1/18,409,091 to 1/11.20 seconds	
		1/4 Clock	1/9,204,545 to 1/5.60 seconds	
	Gain	Auto / Manual (software selectable)		
Gamma	Manual (software selectable)			
White Balance	Auto / Manual / One shot (software selectable)	-		
Trigger Mode	Free-run / Edge preset trigger / Pulse width trigger / Start & stop trigger (software selectable)			
Input/Output	USB 2.0 High Speed			
Power	Input Voltage	+5Vdc through USB connector (+4.4 to +5.25V)		
	Consumption	< 300 mA		
Mechanical Specifications	Dimensions	28 (W) x 28 (H) x 37 (D) mm (excluding connector)		
	Lens Mount	CS mount		
	Weight	Approximately 45g		
	Interface Connector	USB: mini-B USB connector IO signal: 6pin connector (HR10A-7R-6PB or equivalent)		
Environmental Specifications	Operational Temperature	0°C ~ 40°C		
	Storage Temperature	-30°C ~ 65°C		
	Vibration	20 Hz to 200Hz to 20Hz (5min./cycle), acceleration 10G, 3 directions 30 min. each		
	Shock	Acceleration 70G, half amplitude 6ms, 3 directions 3 times each		
	Standard Compliancy	EMS: EN61000-6-2, EMI: EN61000-6-3 (Class B)		
	RoHS	RoHS Compliant		

Caution: Please DO NOT connect or disconnect any USB devices (including the USB memory) while using the Sentech USB camera; this may cause the USB camera to NOT be recognized.

Spectral Sensitivity Characteristics

STC-MC133USB (with IR cut filter)

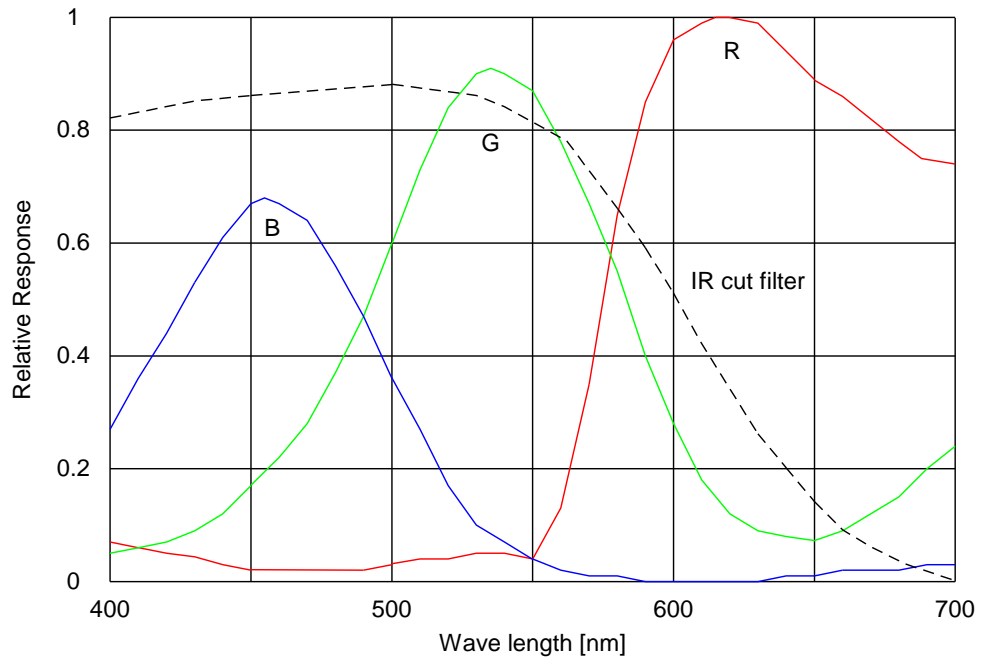

STC-MB133USB

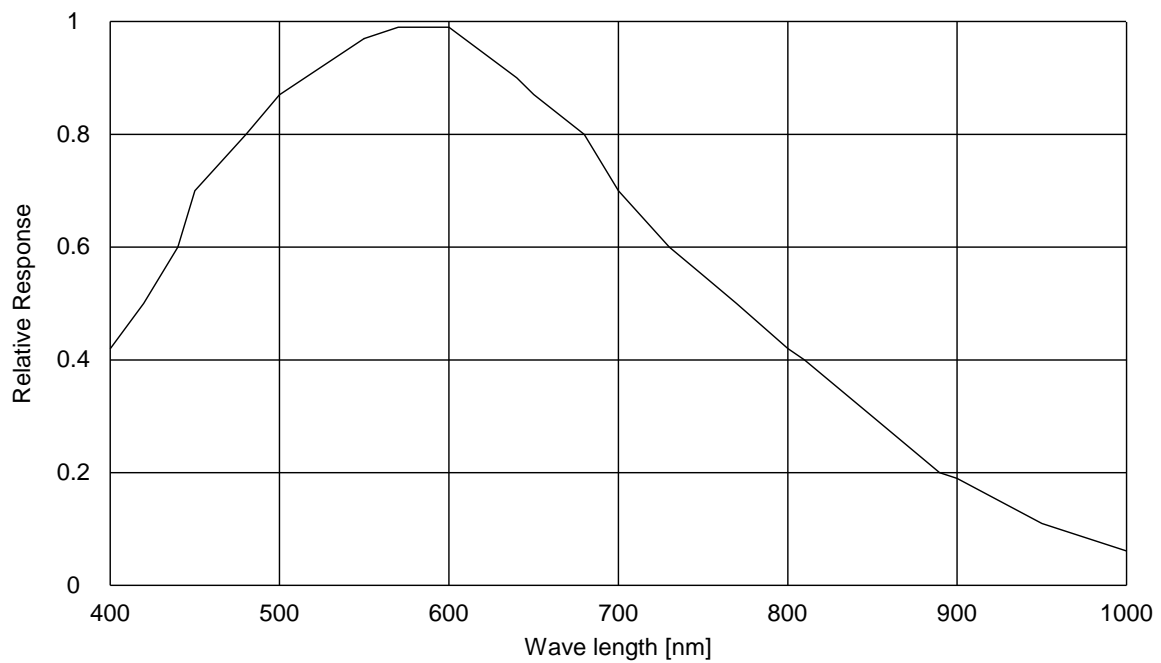

4. STC-MC152USB/STC-MB152USB

Product		STC-MC152USB	STC-MB152USB	
Electronic Specifications	Image Sensor	1/2" Interline SXGA color progressive CCD: ICX205AK (Sony)	1/2" Interline SXGA monochrome progressive CCD: ICX205AL (Sony)	
	Total Picture Element	1434 (H) x 1050 (V)		
	Effective Picture Element	1392 (H) x 1040 (V)		
	Chip Size	7.60 (H) x 6.20 (V) mm		
	Cell Size	4.65 (H) x 4.65 (V) μm		
	Scanning Systems	Progressive		
	Resolution	1360 (H) x 1024 (V) (Full scanning) 1360 (H) x 476 (V) (1/2 partial scanning) 1360 (H) x 184 (V) (1/4 partial scanning)		
	Scanning Methods	Full scanning 1/1 partial scanning 1/2 partial scanning 1/4 partial scanning Variable partial scanning	Full scanning, 1/1 partial scanning, 1/2 partial scanning, 1/4 partial scanning, Variable partial scanning, Binning scanning, Binning 1/1 partial scanning, Binning 1/2 partial scanning, Binning 1/4 partial scanning, Binning variable partial scanning	
	Maximum Frame Rate	Full Scanning	19.26 fps (Normal) / 9.63 fps (1/2 clock) / 4.815 fps (1/4 clock)	
		1/2 Partial Scanning	38.52 fps (Normal) / 19.26 fps (1/2 clock) / 9.63 fps (1/4 clock)	
		1/4 Partial Scanning	77.04 fps (Normal) / 38.52 fps (1/2 clock) / 19.26 fps (1/4 clock)	
	Pixel Frequency	36.818 MHz (Normal) / 18.409 MHz (1/2 clock) / 9.20453 MHz (1/4 clock)		
	Video Output	8bit / 10bit / 12bit		
	Minimum Scene Illumination	18 Lux at F1.2	0.47 Lux at F1.2	
	Sync. System	Internal		
	Electronic Shutter		Auto / Manual (software selectable)	
		Normal	1/36,818,18 to 1/19.26 seconds	
		1/2 Clock	1/18,409,091 to 1/9.63 seconds	
		1/4 Clock	1/9,204,545 to 1/4.81 seconds	
	Gain	Auto / Manual (software selectable)		
Gamma	Manual (software selectable)			
White Balance	Auto / Manual / One shot (software selectable)	-		
Trigger Mode	Free-run / Edge preset trigger / Pulse width trigger / Start & stop trigger (software selectable)			
Input/Output	USB 2.0 High Speed			
Power	Input Voltage	+5Vdc through USB connector (+4.4 to +5.25V)		
	Consumption	< 420 mA		
Mechanical Specifications	Dimensions	28 (W) x 28 (H) x 42 (D) mm (excluding connector)		
	Lens Mount	C mount		
	Weight	Approximately 45g		
	Interface Connector	USB: mini-B USB connector IO signal: 6pin connector (HR10A-7R-6PB or equivalent)		
Environmental Specifications	Operational Temperature	0°C ~ 40°C		
	Storage Temperature	-30°C ~ 65°C		
	Vibration	20 Hz to 200Hz to 20Hz (5min./cycle), acceleration 10G, 3 directions 30 min. each		
	Shock	Acceleration 70G, half amplitude 6ms, 3 directions 3 times each		
	Standard Compliancy	EMS: EN61000-6-2, EMI: EN61000-6-3 (Class B)		
	RoHS	RoHS Compliant		

Caution: Please DO NOT connect or disconnect any USB devices (including the USB memory) while using the Sentech USB camera; this may cause the USB camera to NOT be recognized.

Spectral Sensitivity Characteristics

STC-MC152USB (with IR cut filter)

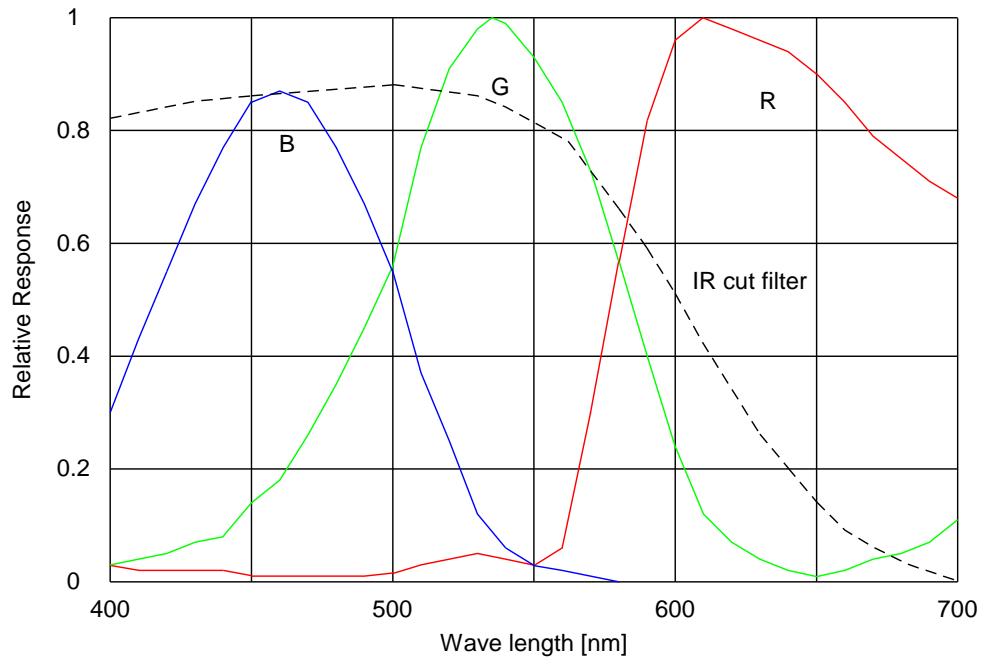

STC-MB152USB

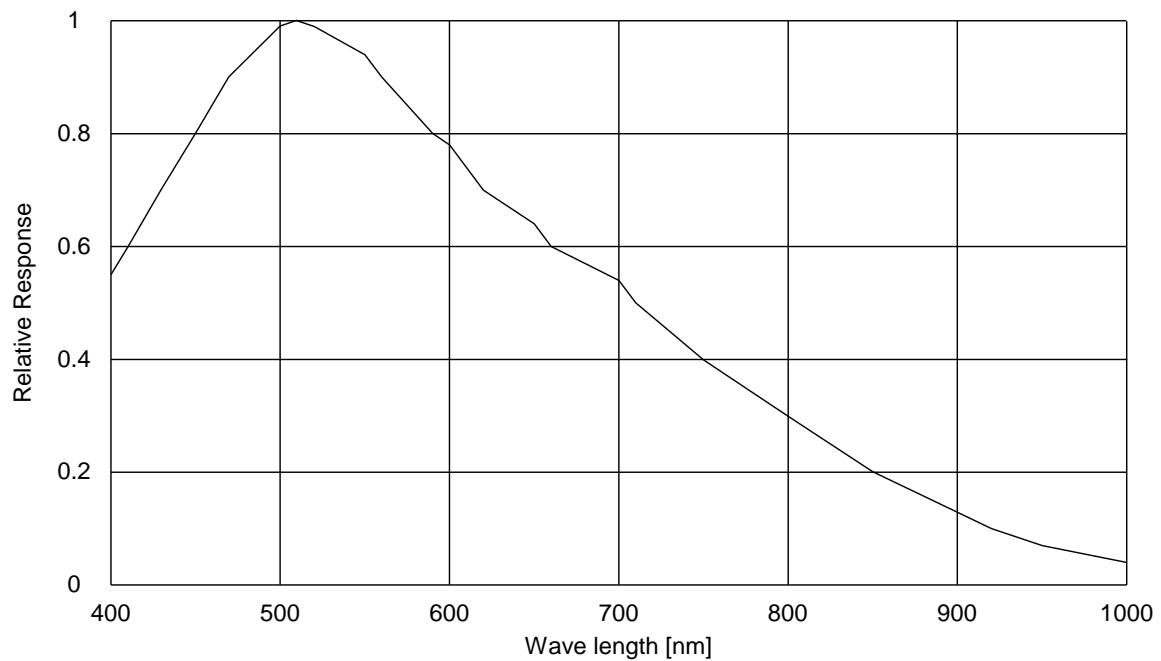

5. STC-MC202USB/STC-MB202USB

Product		STC-MC202USB	STC-MB202USB	
Electronic Specifications	Image Sensor	1/1.8" Interline UXGA color progressive CCD: ICX274AQ (Sony)	1/1.8" Interline UXGA monochrome progressive CCD: ICX274AL (Sony)	
	Total Picture Element	1688 (H) x 1248 (V)		
	Effective Picture Element	1628 (H) x 1236 (V)		
	Chip Size	8.50 (H) x 6.80 (V) mm		
	Cell Size	4.40 (H) x 4.40 (V) μ m		
	Scanning Systems	Progressive		
	Resolution	1600 (H) x 1200 (V) (Full scanning) 1600 (H) x 544 (V) (1/2 partial scanning) 1600 (H) x 208 (V) (1/4 partial scanning)		
	Scanning Methods	Full scanning 1/1 partial scanning 1/2 partial scanning 1/4 partial scanning Variable partial scanning	Full scanning, 1/1 partial scanning, 1/2 partial scanning, 1/4 partial scanning, Variable partial scanning, Binning scanning, Binning 1/1 partial scanning, Binning 1/2 partial scanning, Binning 1/4 partial scanning, Binning variable partial scanning	
	Maximum Frame Rate	Full Scanning	15.32 fps (Normal) / 7.66 fps (1/2 clock) / 3.83 fps (1/4 clock)	
		1/2 Partial Scanning	30.63 fps (Normal) / 15.31 fps (1/2 clock) / 7.65 fps (1/4 clock)	
		1/4 Partial Scanning	61.27 fps (Normal) / 30.63 fps (1/2 clock) / 15.31 fps (1/4 clock)	
	Pixel Frequency	36.818 MHz (Normal) / 18.409 MHz (1/2 clock) / 9.20453 MHz (1/4 clock)		
	Video Output	8bit / 10bit / 12bit		
	Minimum Scene Illumination	7.7 Lux at F1.2	0.13 Lux at F1.2	
	Sync. System	Internal		
	Electronic Shutter		Auto / Manual (software selectable)	
		Normal	1/36,818,18 to 1/15.32 seconds	
		1/2 Clock	1/18,409,091 to 1/7.66 seconds	
		1/4 Clock	1/9,204,545 to 1/3.83 seconds	
	Gain	Auto / Manual (software selectable)		
Gamma	Manual (software selectable)			
White Balance	Auto / Manual / One shot (software selectable)	-		
Trigger Mode	Free-run / Edge preset trigger / Pulse width trigger / Start & stop trigger (software selectable)			
Input/Output	USB 2.0 High Speed			
Power	Input Voltage	+5Vdc through USB connector (+4.4 to +5.25V)		
	Consumption	< 450 mA		
Mechanical Specifications	Dimensions	28 (W) x 28 (H) x 42 (D) mm (excluding connector)		
	Lens Mount	C mount		
	Weight	Approximately 45g		
	Interface Connector	USB: mini-B USB connector IO signal: 6pin connector (HR10A-7R-6PB or equivalent)		
Environmental Specifications	Operational Temperature	0°C ~ 40°C		
	Storage Temperature	-30°C ~ 65°C		
	Vibration	20 Hz to 200Hz to 20Hz (5min./cycle), acceleration 10G, 3 directions 30 min. each		
	Shock	Acceleration 70G, half amplitude 6ms, 3 directions 3 times each		
	Standard Compliancy	EMS: EN61000-6-2, EMI: EN61000-6-3 (Class B)		
	RoHS	RoHS Compliant		

Caution: Please DO NOT connect or disconnect any USB devices (including the USB memory) while using the Sentech USB camera; this may cause the USB camera to NOT be recognized.

Spectral Sensitivity Characteristics

STC-MC202USB (with IR cut filter)

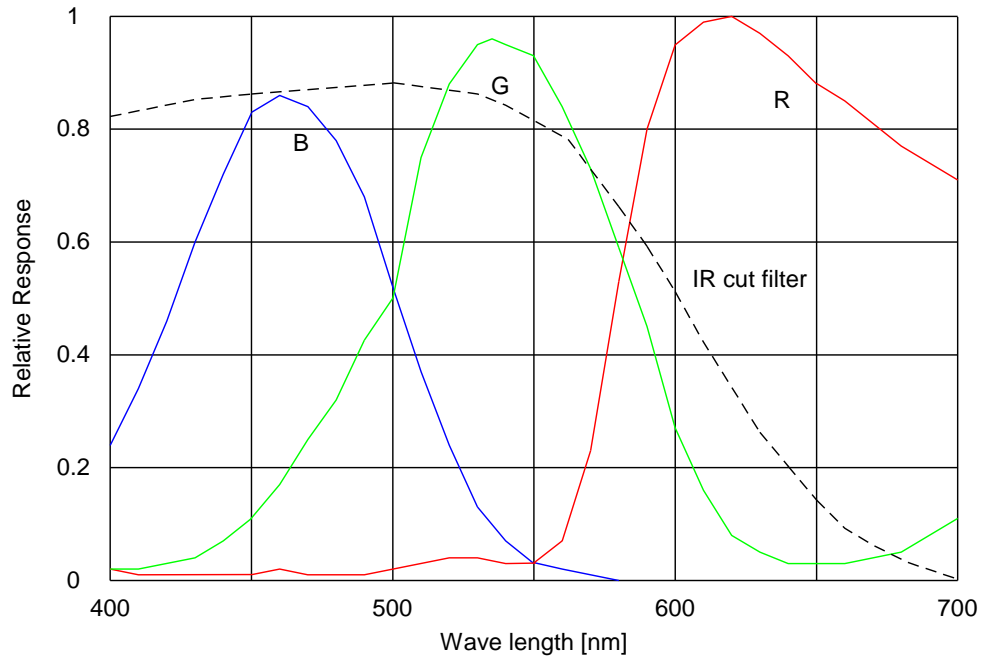

STC-MB202USB

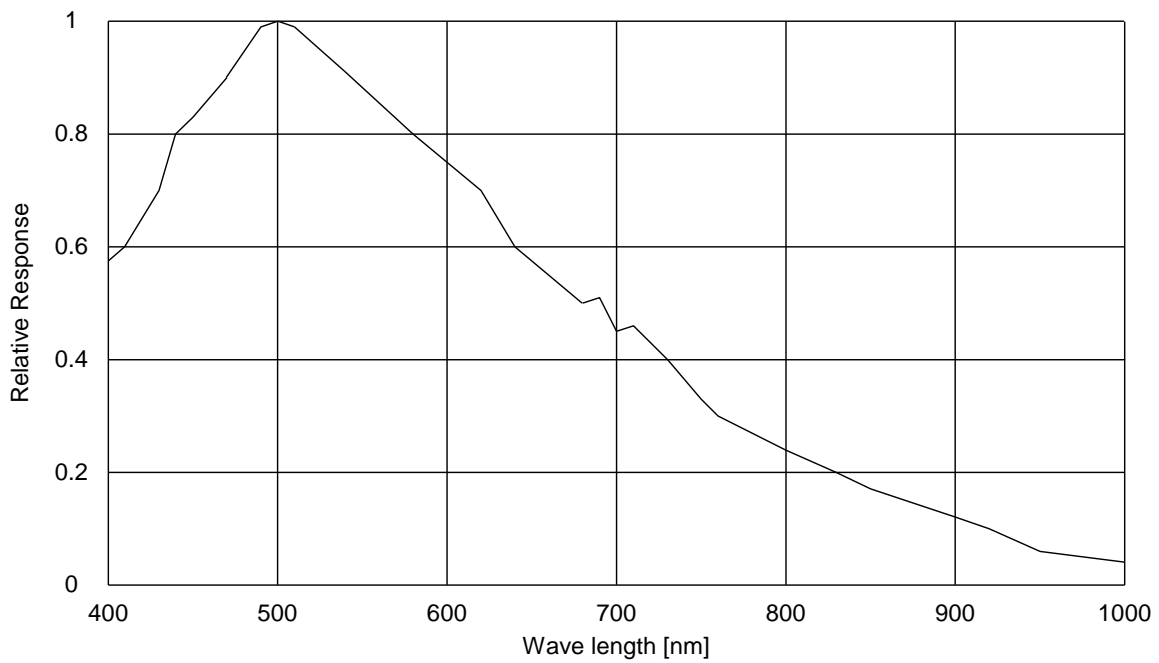

B. Interface Connector

USB Connector: Mini-B USB type

I/O Connector: HR10A-7R-6PB (Hirose) or equivalent
 This connector is for the input and output signals
 The trigger input and the output signals can be assigned through the camera setting communication.
 The power in the connector is for the input/output signals, NOT to power the camera.

Pin Assignment

I/O Connector Pin Assignment

No.	Signal Type	IO Direction	Spec	Initial Signal
1	IO GND	-	IO GND	-
2	OUT2	OUT	Opt. Isolated	No Signal
3	OUT1	OUT	Opt. Isolated	No Signal
4	IN2	IN	Opt. Isolated	No Signal
5	IN1	IN	Opt. Isolated	No Signal
6	IO VCC IN	-	IO VCC +3 to +26.4 Vdc	-

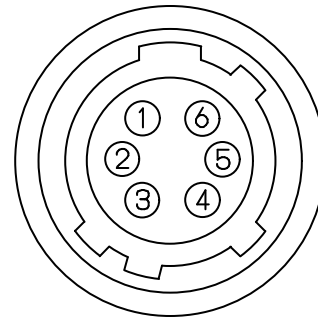

Input and output signals are isolated.

[Connector on the rear panel]

C. Input / Output Signal Specifications

1. Input Signal Specifications

a. Functions of the Input Signals

The following functions can be configured for the input signals (IN1 and IN2) through the software:

No	Functions	Polarity
1	No Signal (Default)	-
2	General Input	-
3	Trigger Signal Input	Positive / Negative
4	Read Out Signal Input	Positive / Negative
5	Sub Trigger Signal Input	Positive / Negative

The polarity for the Trigger Signal Input, the Read Out Signal Input, and the Sub Trigger Signal Input is selectable via software. (Note: It is recommended to set negative polarity to reduce the timing delay of the photo-coupler.)

b. Characteristics of the Input Signals

Input Signal Level: High: IO VCC IN (+3 to +26.4V)

Low: Less than 0.4V

Input Signal Duration: The signal duration should be longer than “Tf+Tr”
 Please check the “Input signal response timings” for Tf and Tr.

Input Signal Response Timings:

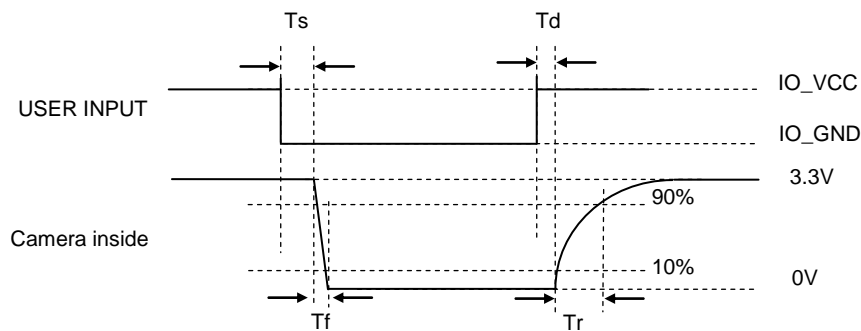

	IO_VCC			
	3.3[V]	5.0[V]	12[V]	24[V]
Td	35.2 [us]	38.2 [us]	39.6 [us]	39.6 [us]
Tr	23.8 [us]	24.0 [us]	23.6 [us]	23.6 [us]
Ts	2.6 [us]	2.16 [us]	1.8 [us]	1.76 [us]
Tf	3.36 [us]	2.28 [us]	2.0 [us]	1.88 [us]

c. Input Signal Circuits

Example Circuits 1

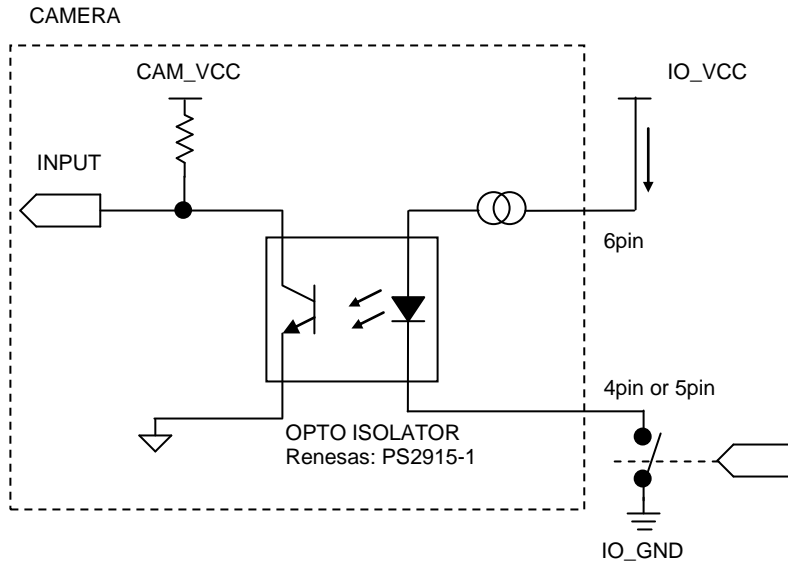

Example Circuits 2

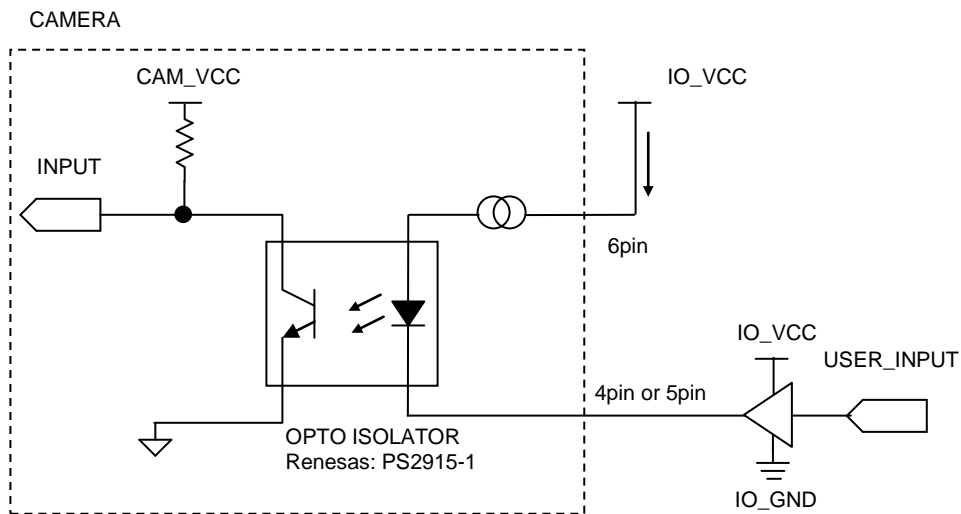

2. Output Signal Specifications

a. Functions for the Output Signals

The following functions can be configured for the output signals (OUT1 and OUT2) through the software:

No.	Functions	Polarity
1	No Signal (Default)	-
2	General Input	-
3	Trigger Signal Output	Positive / Negative
4	Exposure End Signal Output	Positive / Negative
5	CCD Read Out End Signal Output	Positive / Negative
6	Strobe Signal Output (Time Setting)	Positive / Negative
7	Strobe Signal Output (Exposure Time)	Positive / Negative

The polarity for the Trigger Signal Output, the Exposure End Signal Output, the CCD Read Out End Signal Output, the Strobe Signal Output (Time Setting) and Strobe Signal Output (Exposure Time) is selectable via software.

(Note: It is recommended to set negative polarity to reduce the timing delay of the photo-coupler)

b. Characteristics of the Output Signals

Input Signal Level: High: IO VCC IN (+3 to +26.4V)

Low: Less than 0.8V

Input Signal Duration: The signal duration should be longer than "Tf+Tr"
 Please check the "Output signal response timings" for Tf and Tr.
 The signal duration can be adjusted by the software.

Input Signal Response Timings:

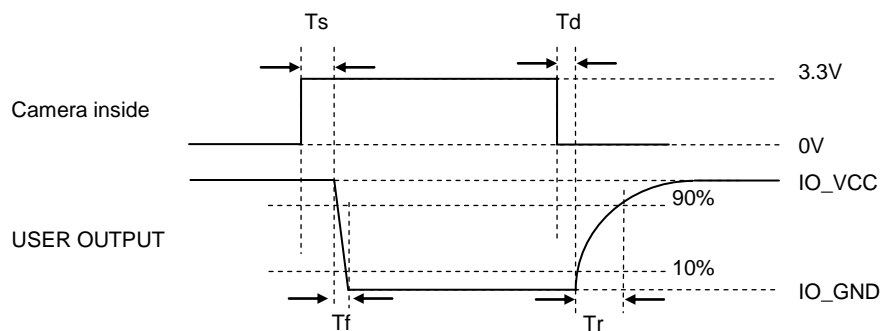

	IO_VCC			
	3.3[V]	5.0[V]	12[V]	24[V]
Td	41.6 [us]	56.8 [us]	49.6 [us]	44.8 [us]
Tr	126 [us]	76.8 [us]	81.6 [us]	49.6 [us]
Ts	1.68 [us]	1.72 [us]	1.70 [us]	1.88 [us]
Tf	1.8 [us]	1.78 [us]	3.34 [us]	4.88 [us]

c. Output Signal Circuits

Example Circuits 1

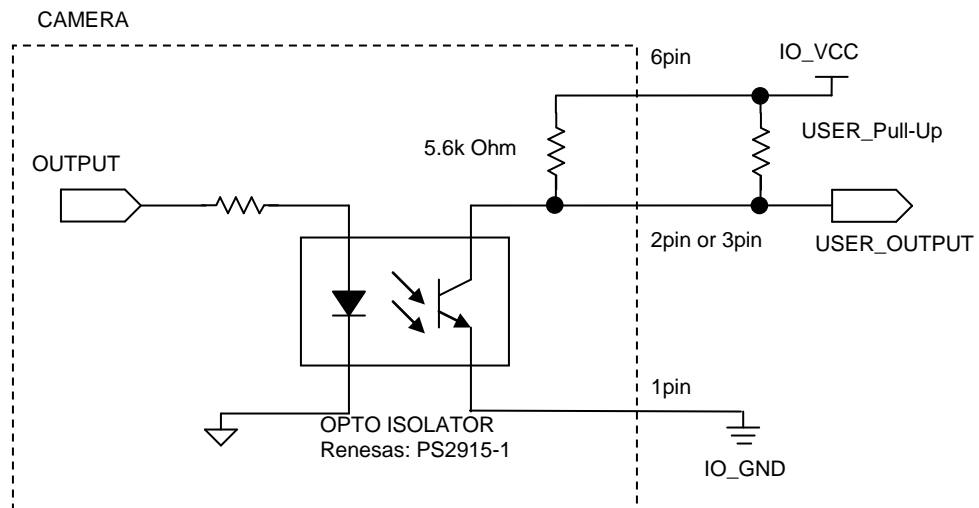

II. Dimensions

1. STC-MB33USB / MC33USB / MB83USB / MC83USB / MB133USB / MC133USB

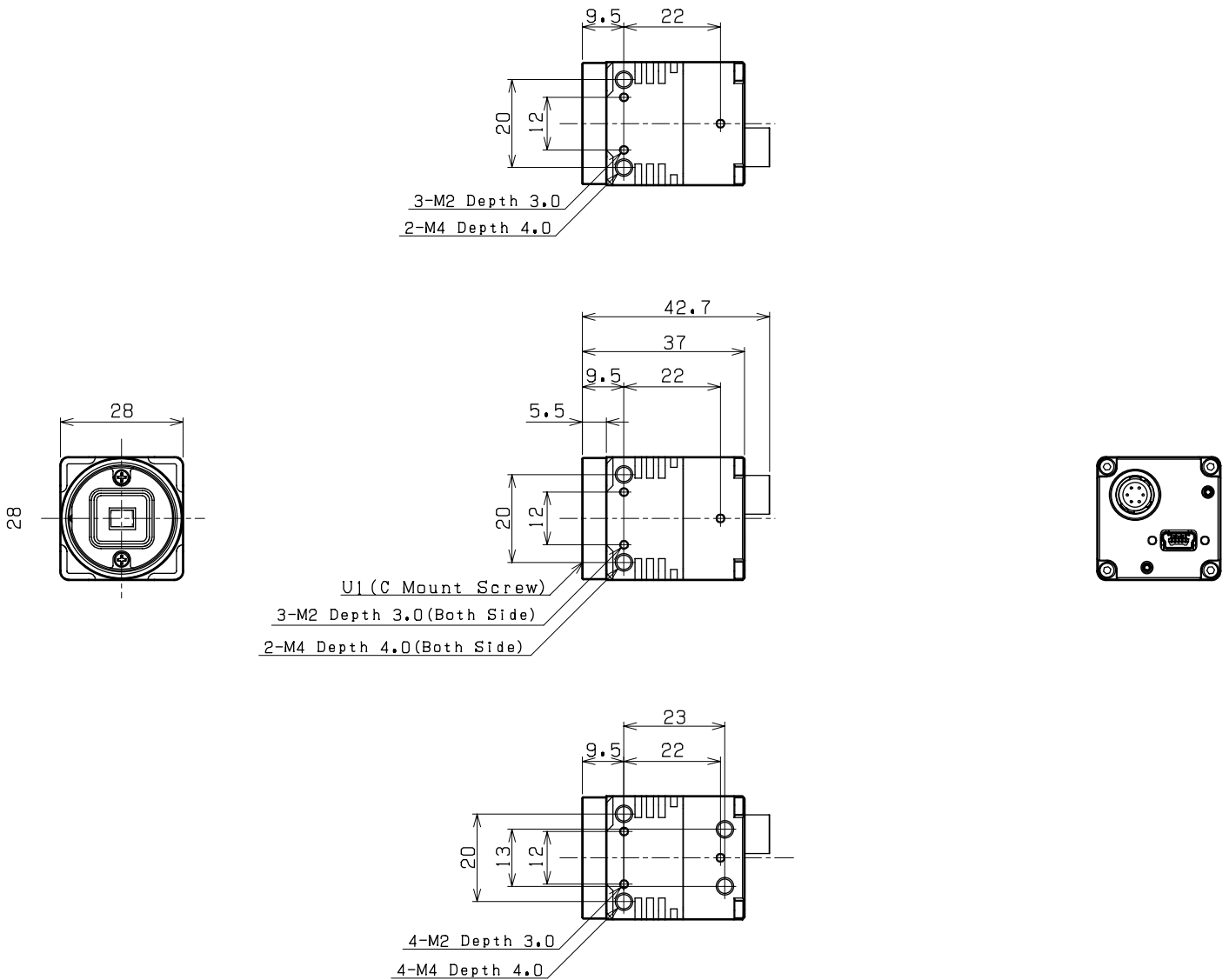

Unit: mm

2. STC-MB33USB / MC33USB / MB83USB / MC83USB / MB133USB / MC133USB (With Tripod)

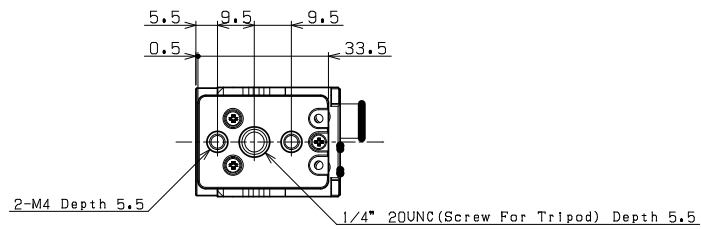
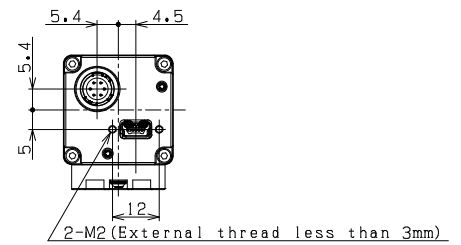
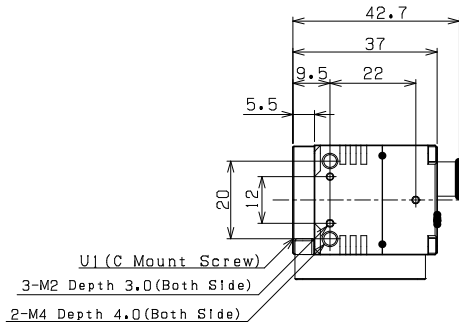
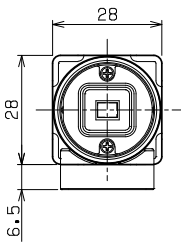
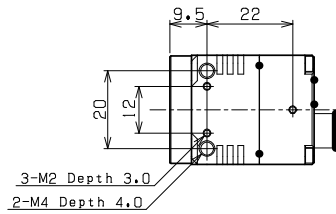
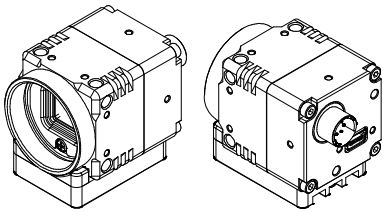

3. STC-MB152USB / MC152USB / MB202USB / MC202USB

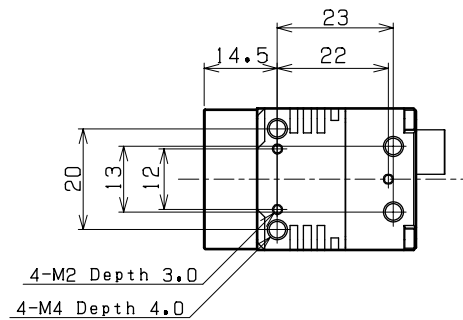
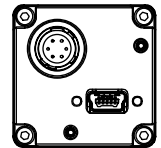
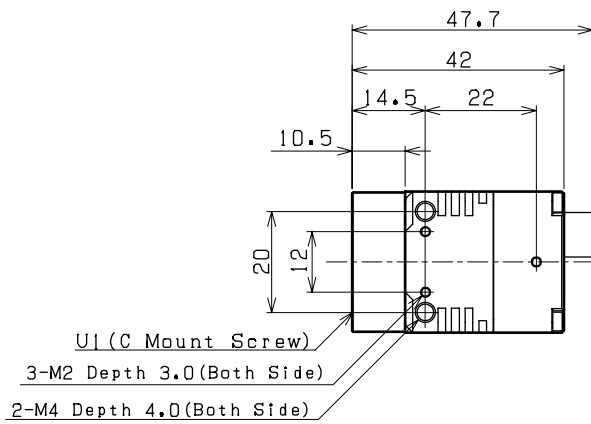
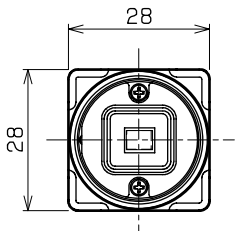
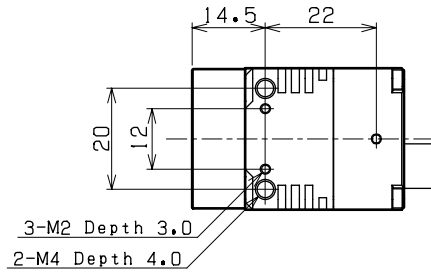

Unit: mm

4. STC-MB152USB / MC152USB / MB202USB / MC202USB (with Tripod)

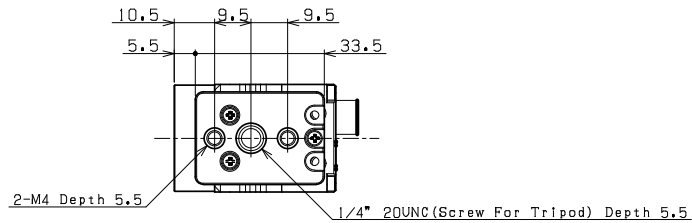
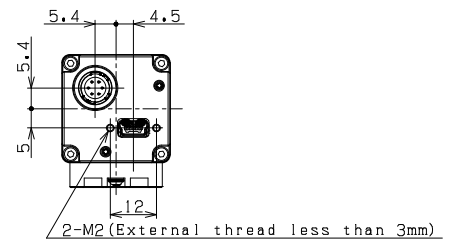
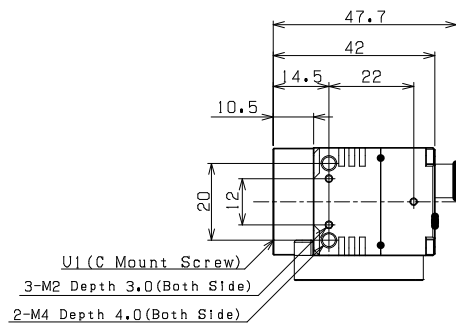
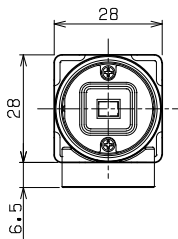
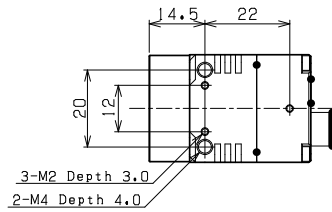
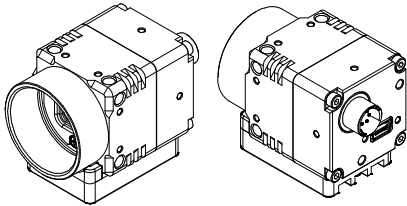

Revisions

Date	Rev.	Change	Notes
Oct. 31, 2011	1.0	New Document	
Nov. 22, 2011	1.01	Changed to include Quad-VGA	
May 20, 2013	1.02	Update Updated effective picture elements.	
April 29, 2014	1.03	Updated	

Senor Technologies America, Inc.
1345 Valwood Parkway, Suite 320
Carrollton, Texas 75006-6891
TEL (972)481-9223 FAX(972) 481-9209
URL <http://www.sentechamerica.com/>

Sensor Technology Co., Ltd.
7F, Harada Center Building
9-17, Naka cho 4 chome
Atsugi-city, Kanagawa
243-0018 Japan
TEL +81-46-295-7061 FAX +81-46-295-7066
URL <http://www.sentech.co.jp/>

Taiwan Sensor Technology, Inc.
3F-6, No. 9, Aiguo W, Rd., Jhong Jheng District
Taipei City 100, Taiwan, R.O.C.
TEL 886-2-2383-2331
FAX 886-2-2370-8775
EMAIL sentech0501@yahoo.com.tw